

# SA-FT7ED/WFT7/SS-CNF7ED/ FRF7ED/WS-FT7

## SERVICE MANUAL

Ver. 1.1 2005. 11

US Model  
Canadian Model  
AEP Model  
UK Model

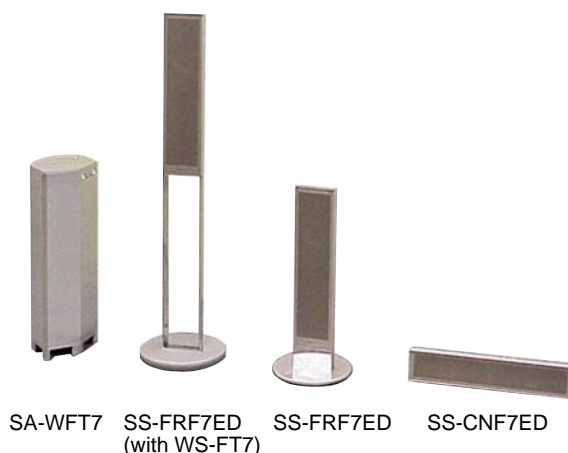

SA-WFT7 SS-FRF7ED (with WS-FT7) SS-FRF7ED SS-CNF7ED

- SA-FT7ED is composed of following models.

### COMPONENT MODEL NAME

FRONT/SURROUND SPEAKER	SS-FRF7ED
CENTER SPEAKER	SS-CNF7ED
SUBWOOFER	SA-WFT7
SPEAKER STAND	WS-FT7

WS-FT7 is not included in US and Canadian model.

### SPECIFICATIONS

#### AUDIO POWER SPECIFICATIONS (US, CND model)

**POWER OUTPUT AND TOTAL HARMONIC DISTORTION:**  
With 4 ohm loads both channels driven, at 100 Hz; rated 250 watts per channel minimum RMS power, with no more than 10% total harmonic distortion from 250 milliwatts to rated output.

#### SS-FRF7ED (front/surround speakers)

Speaker system	2 way, magnetically shielded
Speaker units	Woofer: 10 cm (4 in.), cone type Tweeter: 20 mm (3/4 in.), dome type
Enclosure type	Bass reflex
Rated impedance	8 ohms
Power handling capacity	
Maximum input power:	120 W
Sensitivity level	84 dB (1 W, 1 m)
Frequency range	120 Hz – 70,000 Hz
Dimensions (w/h/d)	Approx. 130 × 510 × 30 mm (5 1/8 × 20 1/8 × 1 3/16 in.)
with floor stand (AEP, UK model)	Approx. 130 × 1,100 × 30 mm (5 1/8 × 43 5/16 × 1 3/16 in.) (Diameter of base: 280 mm (11 1/32 in.))
with table top stand	Approx. 130 × 585 × 30 mm (5 1/8 × 23 1/8 × 1 3/16 in.) (Diameter of base: 250 mm (9 7/8 in.))
with wall mounting bracket	Approx. 130 × 576 × 50 mm (5 1/8 × 22 3/4 × 2 in.)

Mass	Approx. 2.0 kg (4 lb 7 oz)
with floor stand (AEP, UK model)	Approx. 7.7 kg (16 lb 15 oz)
with table top stand	Approx. 3.3 kg (7 lb 4 oz)
with wall mounting bracket	Approx. 2.5 kg (5 lb 9 oz)

#### SS-CNF7ED (center speaker)

Speaker system	2 way, magnetically shielded
Speaker units	Woofer: 8 cm (3 1/4 in.), cone type (× 2) Tweeter: 20 mm (3/4 in.), dome type
Enclosure type	Bass reflex
Rated impedance	8 ohms
Power handling capacity	
Maximum input power:	120 W
Sensitivity level	84 dB (1 W, 1 m)
Frequency range	130 Hz – 70,000 Hz
Dimensions (w/h/d)	Approx. 500 × 94 × 30 mm (19 3/4 × 3 3/4 × 1 3/16 in.)
with table top stand	Approx. 500 × 108 × 66 mm (19 3/4 × 4 3/8 × 2 5/8 in.)
with wall mounting bracket	Approx. 500 × 94 × 42 mm (19 3/4 × 3 3/4 × 1 11/16 in.)

– Continued on next page –

## HOME THEATRE SPEAKER SYSTEM

9-879-750-02

2005K04-1

© 2005. 11

**Sony Corporation**

Home Audio Division

Published by Sony Engineering Corporation

**SONY**®

# SA-FT7ED/WFT7/SS-CNF7ED/FRF7ED/WS-FT7

Mass	Approx. 1.6 kg (3 lb 8 oz)
with table top stand	Approx. 1.8 kg (3 lb 15 oz)
with wall mounting bracket	Approx. 1.7 kg (3 lb 12 oz)

## SA-WFT7 (subwoofer)

Speaker system	Active subwoofer, magnetically shielded
Speaker units	Woofer: 15 cm (6 in.), cone type
Enclosure type	Acoustically Loaded Bass reflex
Reproduction frequency range	26 Hz – 200 Hz
Continuous RMS power output	250 W (4 ohms 100 Hz, 10% THD)

## Input

LINE IN (input pin jack)

## General

Power requirements	
US, CND model:	120 V AC, 60 Hz
AEP, UK model:	220 – 240 V AC, 50/60 Hz
Power consumptions	65 W
	0.3 W (standby mode)
Dimensions (w/h/d)	Approx. 175 × 610 × 298 mm (7 × 24 1/8 × 11 3/4 in.)
Mass	Approx. 11 kg (24 lb 4 oz)

## WS-FT7 (speaker stand)

Dimension (w/h/d)	Approx. 130 × 635 × 30 mm (5 1/8 × 25 × 1 3/16 in.) (Diameter of base: 280 mm (11 1/8 in.))
Mass	Approx. 5.7 kg (12 lb 9 oz)

## Supplied accessories

### SA-FT7ED:

Speaker cord (3.5 m) (3)  
 Speaker cord (10 m) (2)  
 Pin cord (2 m) (1)  
 Floor stand (2) (AEP, UK model)  
 Terminal adapter (4)  
 Table top stand base (4) (US, CND model)  
 Table top stand base (2) (AEP, UK model)  
 Center speaker stand base (1)  
 Center speaker stand adjuster (1)  
 Wall mounting bracket (for the front/surround speakers) (4)  
 Wall mounting bracket (for the center speaker) (1)  
 Wall mounting hook (10)  
 Hex-head screw (8)  
 Screw (M5) (18) (US, CND model)  
 Screw (M5) (10) (AEP, UK model)  
 Screw (M4) (20)  
 Wrench (1)  
 L-adapter (1)  
 Sticker for the speakers (1)  
 Sticker for the terminal adapters (4)  
 Cleaning cloth (1)

### SS-FRF7ED:

Speaker cord (10 m) (1)  
 Terminal adapter (1)  
 Table top stand base (1)  
 Wall mounting bracket (speaker side) (1)  
 Wall mounting bracket (wall side) (1)  
 Wall mounting hook (2)  
 Hex-head screw (2)  
 Screw (M5) (4)  
 Screw (M4) (4)  
 Screw (for wall mounting bracket) (2)  
 Wrench (1)  
 Sticker for the speakers (1)  
 Sticker for the terminal adapters (1)  
 Cleaning cloth (1)

### WS-FT7:

Cleaning cloth (1)

Design and specifications are subject to change without notice.

• Abbreviation  
 CND: Canadian model

## SAFETY CHECK-OUT

After correcting the original service problem, perform the following safety check before releasing the set to the customer:

Check the antenna terminals, metal trim, “metallized” knobs, screws, and all other exposed metal parts for AC leakage. Check leakage as described below.

## LEAKAGE TEST

The AC leakage from any exposed metal part to earth ground and from all exposed metal parts to any exposed metal part having a return to chassis, must not exceed 0.5 mA (500 microamperes). Leakage current can be measured by any one of three methods.

1. A commercial leakage tester, such as the Simpson 229 or RCA WT-540A. Follow the manufacturers’ instructions to use these instruments.
2. A battery-operated AC milliammeter. The Data Precision 245 digital multimeter is suitable for this job.
3. Measuring the voltage drop across a resistor by means of a VOM or battery-operated AC voltmeter. The “limit” indication is 0.75 V, so analog meters must have an accurate low-voltage scale. The Simpson 250 and Sanwa SH-63Trd are examples of a passive VOM that is suitable. Nearly all battery operated digital multimeters that have a 2V AC range are suitable. (See Fig. A)

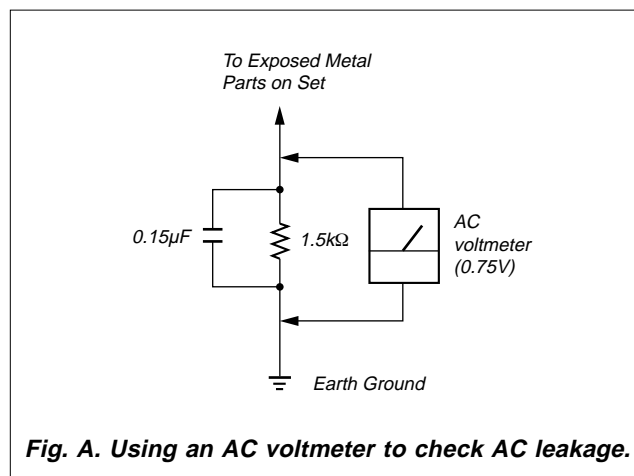

## SAFETY-RELATED COMPONENT WARNING!!

COMPONENTS IDENTIFIED BY MARK  $\Delta$  OR DOTTED LINE WITH MARK  $\Delta$  ON THE SCHEMATIC DIAGRAMS AND IN THE PARTS LIST ARE CRITICAL TO SAFE OPERATION. REPLACE THESE COMPONENTS WITH SONY PARTS WHOSE PART NUMBERS APPEAR AS SHOWN IN THIS MANUAL OR IN SUPPLEMENTS PUBLISHED BY SONY.

## ATTENTION AU COMPOSANT AYANT RAPPORT À LA SÉCURITÉ!!

LES COMPOSANTS IDENTIFIÉS PAR UNE MARQUE  $\Delta$  SUR LES DIAGRAMMES SCHÉMATIQUES ET LA LISTE DES PIÈCES SONT CRITIQUES POUR LA SÉCURITÉ DE FONCTIONNEMENT. NE REMPLACER CES COMPOSANTS QUE PAR DES PIÈCES SONY DONT LES NUMÉROS SONT DONNÉS DANS CE MANUEL OU DANS LES SUPPLÉMENTS PUBLIÉS PAR SONY.

## TABLE OF CONTENTS

### 1. SERVICING NOTES

1-1. Service Position (SA-WFT7) .....	4
1-2. Note for Replacement of the Speaker Unit (SA-WFT7) .....	4
1-3. Note for Disassembly of the Top Cover (SS-FRF7ED) and Side Cover (SS-CNF7ED) .....	5

### 2. DISASSEMBLY

2-1. Top Cover .....	6
2-2. AMP Board, FILTER Board .....	7
2-3. POWER Board .....	7
2-4. Bottom Cover (B) Assy .....	8
2-5. INPUT Board .....	8
2-6. ACIN Board .....	9

### 3. DIAGRAMS

3-1. Circuit Boards Location .....	10
3-2. Block Diagram .....	11
3-3. Printed Wiring Boards –Filter Section– .....	12
3-4. Schematic Diagram –Filter Section– .....	13
3-5. Printed Wiring Board –Amp Section (1/2)– .....	14
3-6. Printed Wiring Board –Amp Section (2/2)– .....	15
3-7. Schematic Diagram –Amp Section– .....	16
3-8. Printed Wiring Boards –Power Section– .....	17
3-9. Schematic Diagram –Power Section– .....	18

### 4. EXPLODED VIEWS

4-1. Front/Surround Speaker Section (SS-FRF7ED) .....	21
4-2. Center Speaker Section (SS-CNF7ED) .....	22
4-3. Speaker Stand Section (WS-FT7) .....	23
4-4. Subwoofer Section (1) (SA-WFT7) .....	24
4-5. Subwoofer Section (2) (SA-WFT7) .....	25
4-6. Bracket, Base Section .....	26

5. ELECTRICAL PARTS LIST .....	27
--------------------------------	----

# SA-FT7ED/WFT7/SS-CNF7ED/FRF7ED/WS-FT7

## SECTION 1

### SERVICING NOTES

#### 1-1. SERVICE POSITION (SA-WFT7)

When repairing or servicing this set, arrange the boards as shown below.

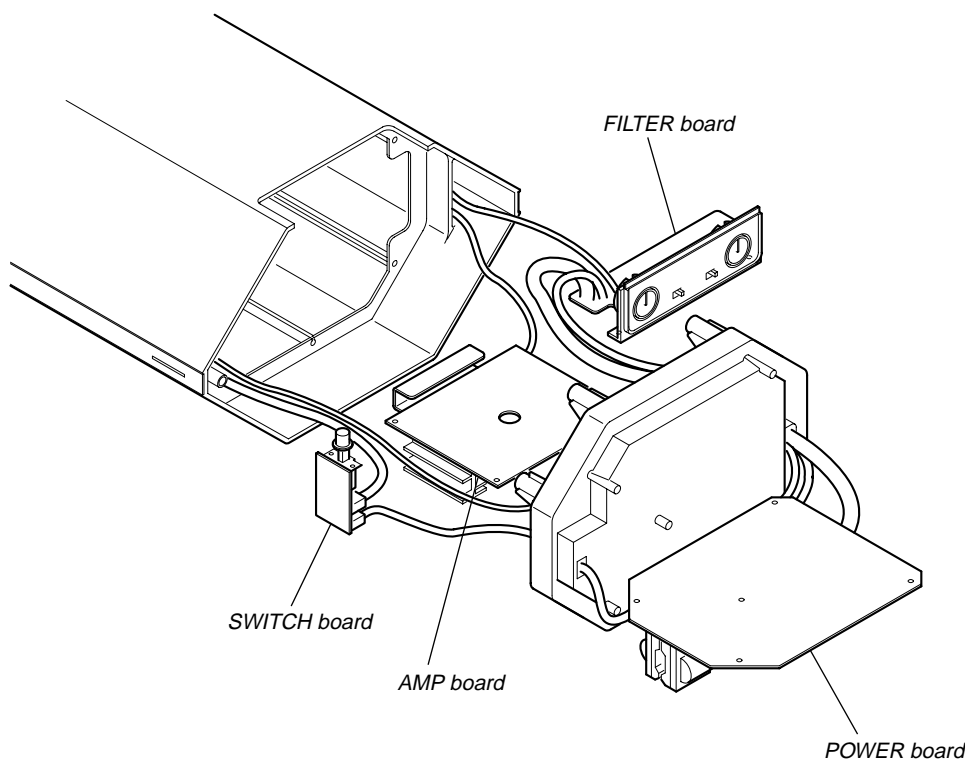

#### 1-2. NOTE FOR REPLACEMENT OF THE SPEAKER UNIT (SA-WFT7)

*Pulled and raised gripping this position with pliers.*

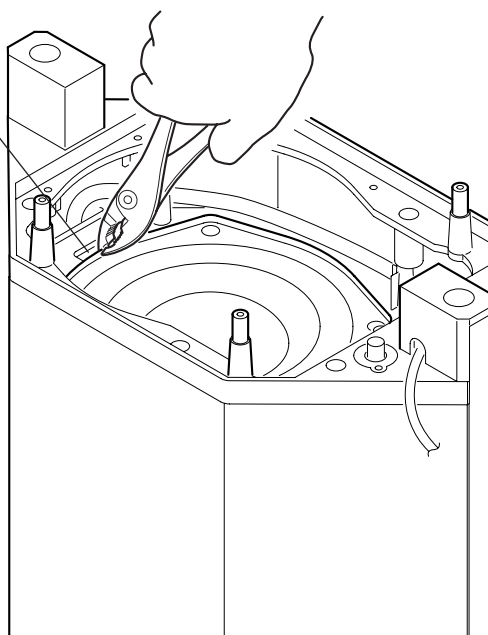

1-3. NOTE FOR DISASSEMBLY OF THE TOP COVER (SS-FRF7ED) AND SIDE COVER (SS-CNF7ED)

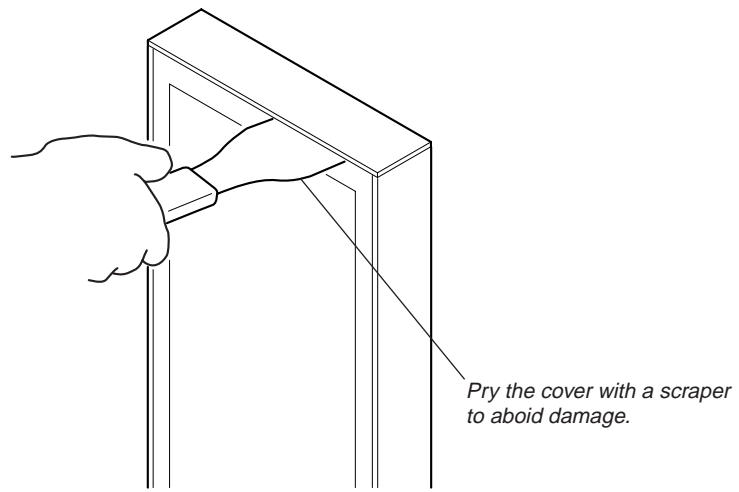

# SA-FT7ED/WFT7/SS-CNF7ED/FRF7ED/WS-FT7

## SECTION 2

### DISASSEMBLY

• The equipment can be removed using the following procedure.

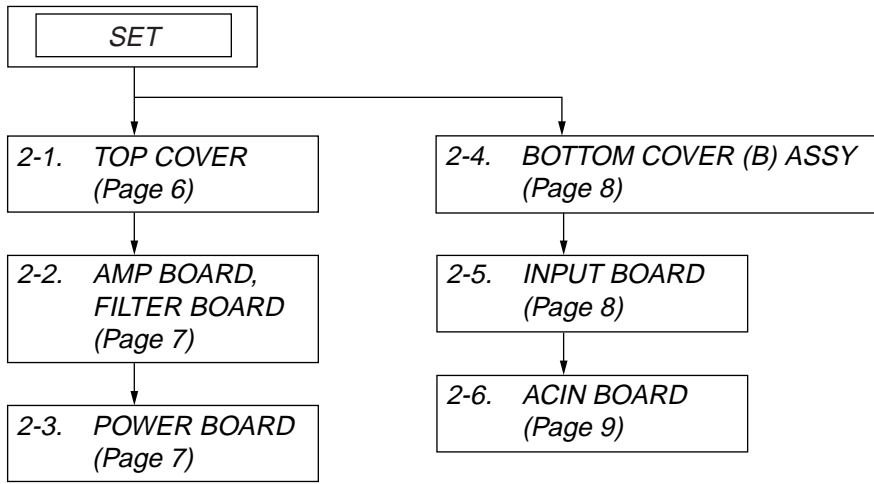

**Note :** Follow the disassembly procedure in the numerical order given.

#### 2-1. TOP COVER

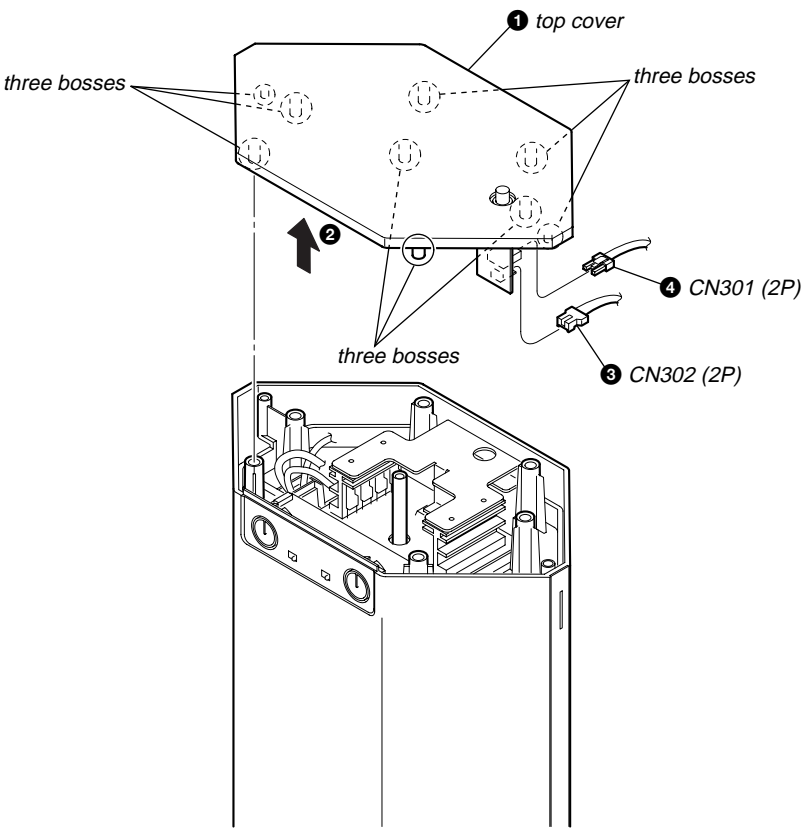

2-2. AMP BOARD, FILTER BOARD

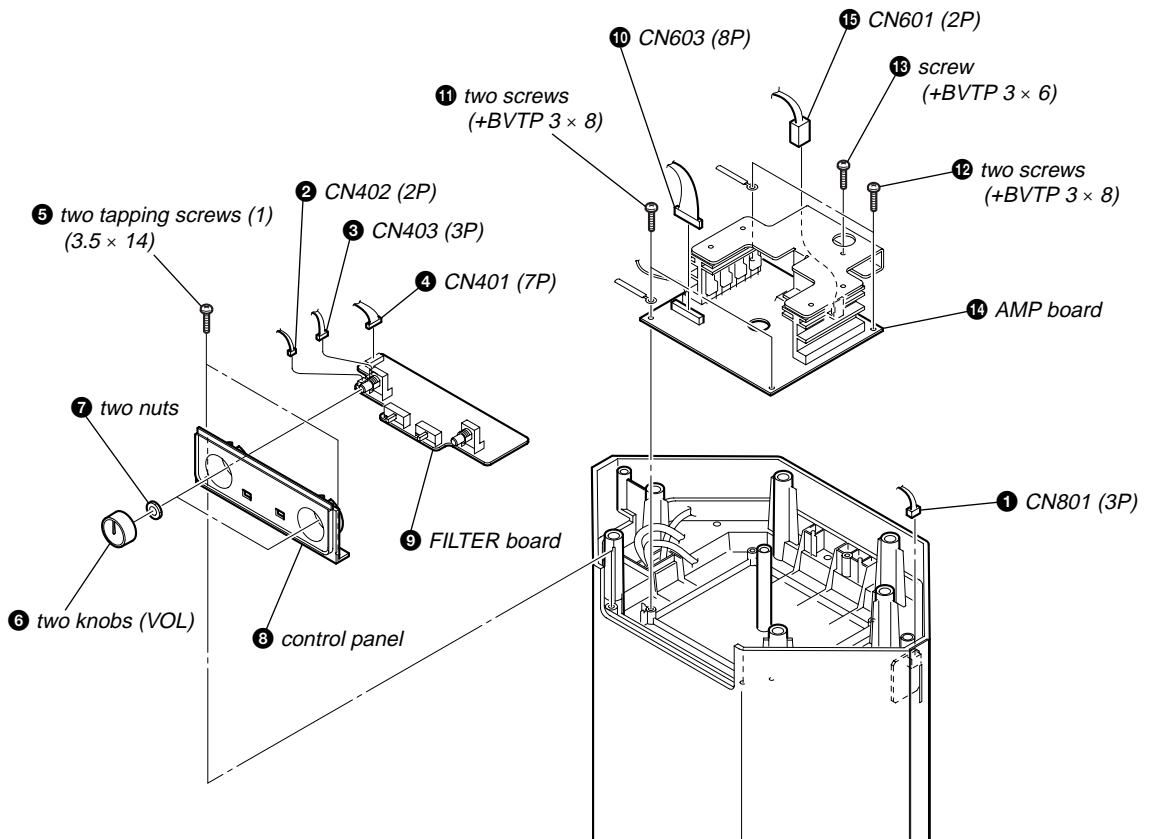

2-3. POWER BOARD

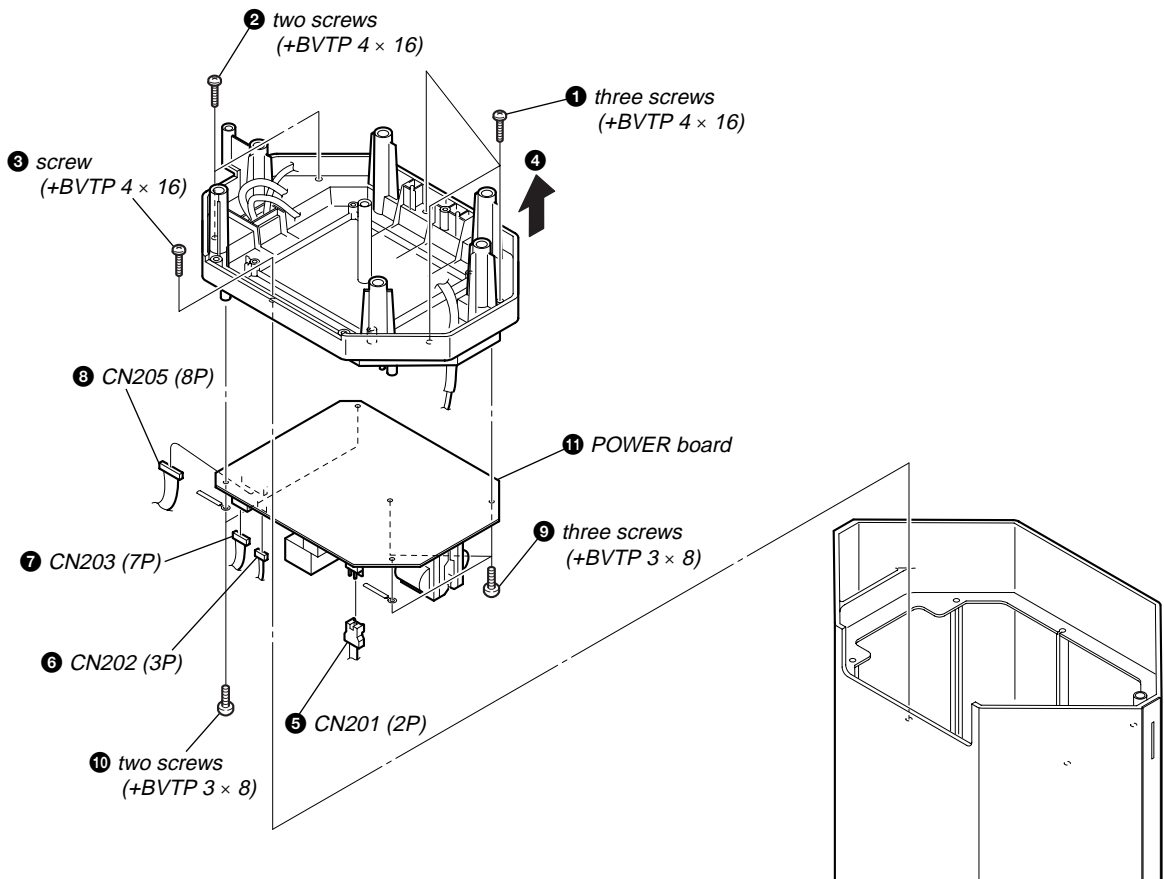

2-4. BOTTOM COVER (B) ASSY

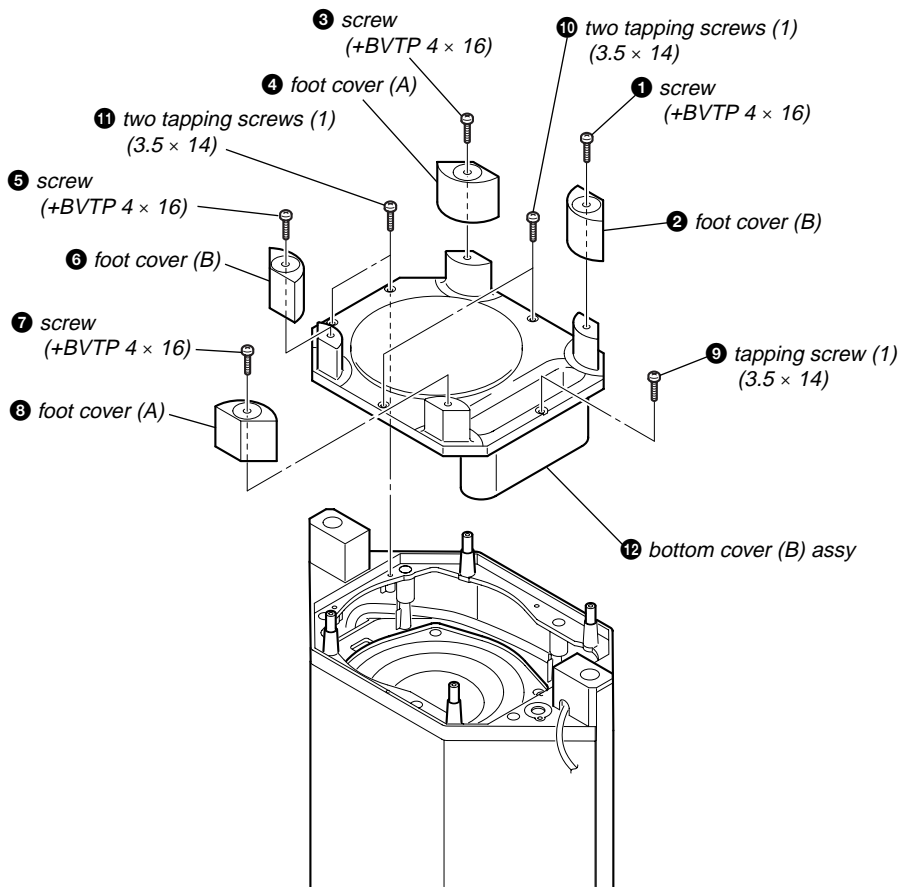

2-5. INPUT BOARD

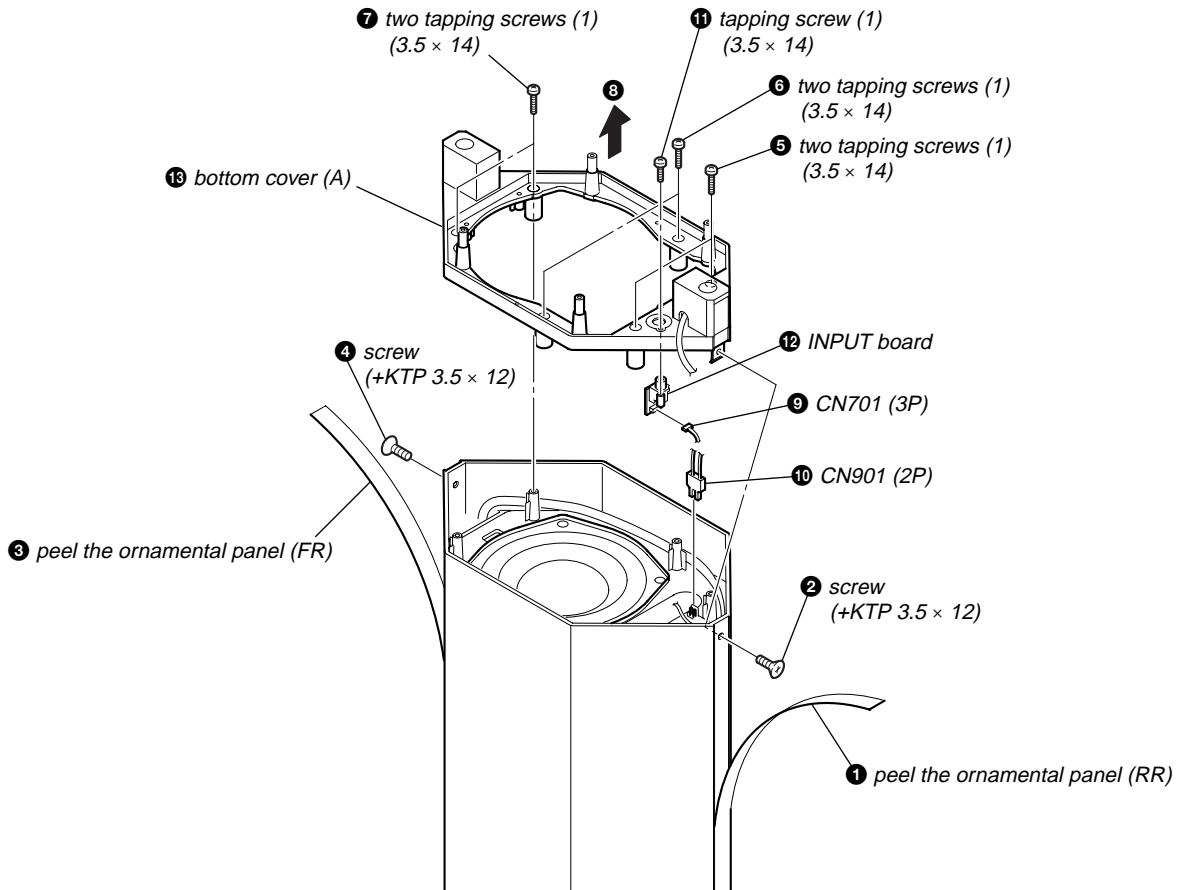



2-6. ACIN BOARD

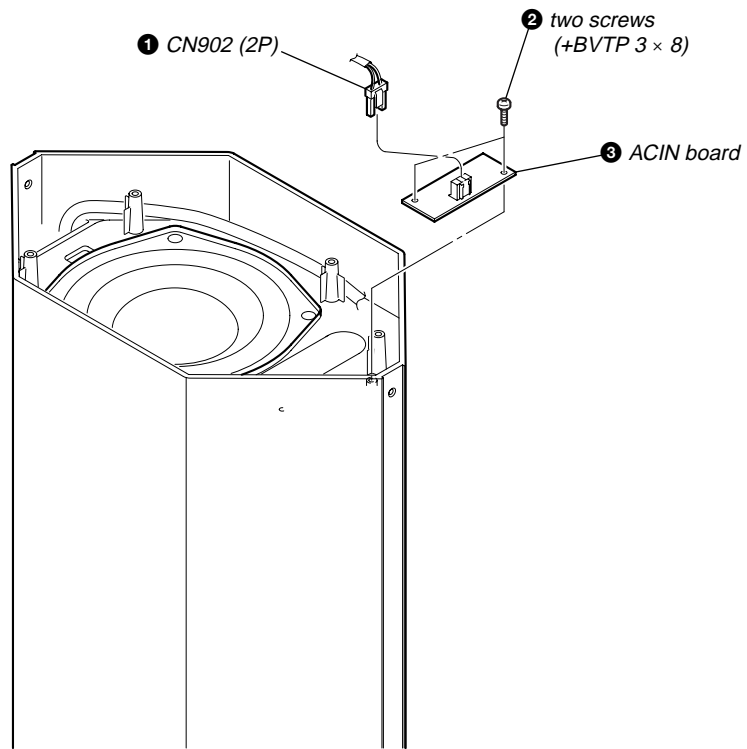

# SA-FT7ED/WFT7/SS-CNF7ED/FRF7ED/WS-FT7

## SECTION 3

### DIAGRAMS

#### 3-1. CIRCUIT BOARDS LOCATION

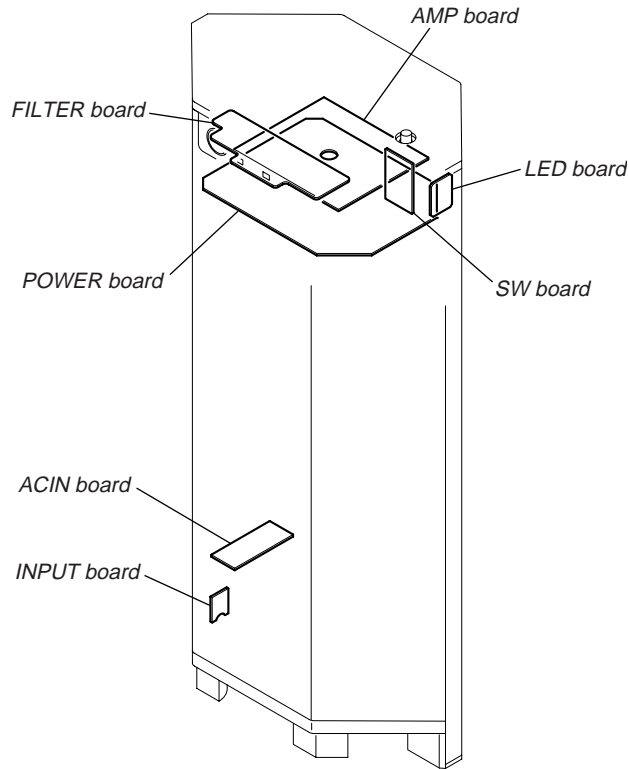

#### Note on Schematic Diagram:

- All capacitors are in  $\mu\text{F}$  unless otherwise noted. (p: pF) 50 WV or less are not indicated except for electrolytics and tantalums.
- All resistors are in  $\Omega$  and  $1/4\text{W}$  or less unless otherwise specified.
- : nonflammable resistor.
- : panel designation.

#### Note:

The components identified by mark  $\Delta$  or dotted line with mark  $\Delta$  are critical for safety. Replace only with part number specified.

#### Note:

Les composants identifiés par une marque  $\Delta$  sont critiques pour la sécurité. Ne les remplacer que par une pièce portant le numéro spécifié.

- : B+ Line.
- : B- Line.
- Voltage is dc with respect to ground under no-signal (detuned) condition.
- Voltages are taken with a VOM (Input impedance  $10\text{M}\Omega$ ). Voltage variations may be noted due to normal production tolerances.
- no mark : POWER ON
- \* : Impossible to measure
- Signal path.
- : LINE
- Abbreviation
- CND : Canadian model.

#### Note on Printed Wiring Boards:

- : parts extracted from the component side.
- : Pattern from the side which enables seeing.
- Abbreviation
- CND : Canadian model.

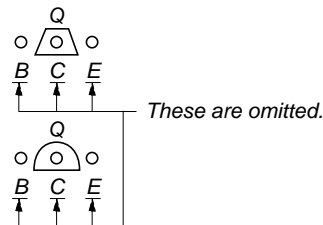
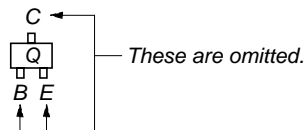

3-2. BLOCK DIAGRAM

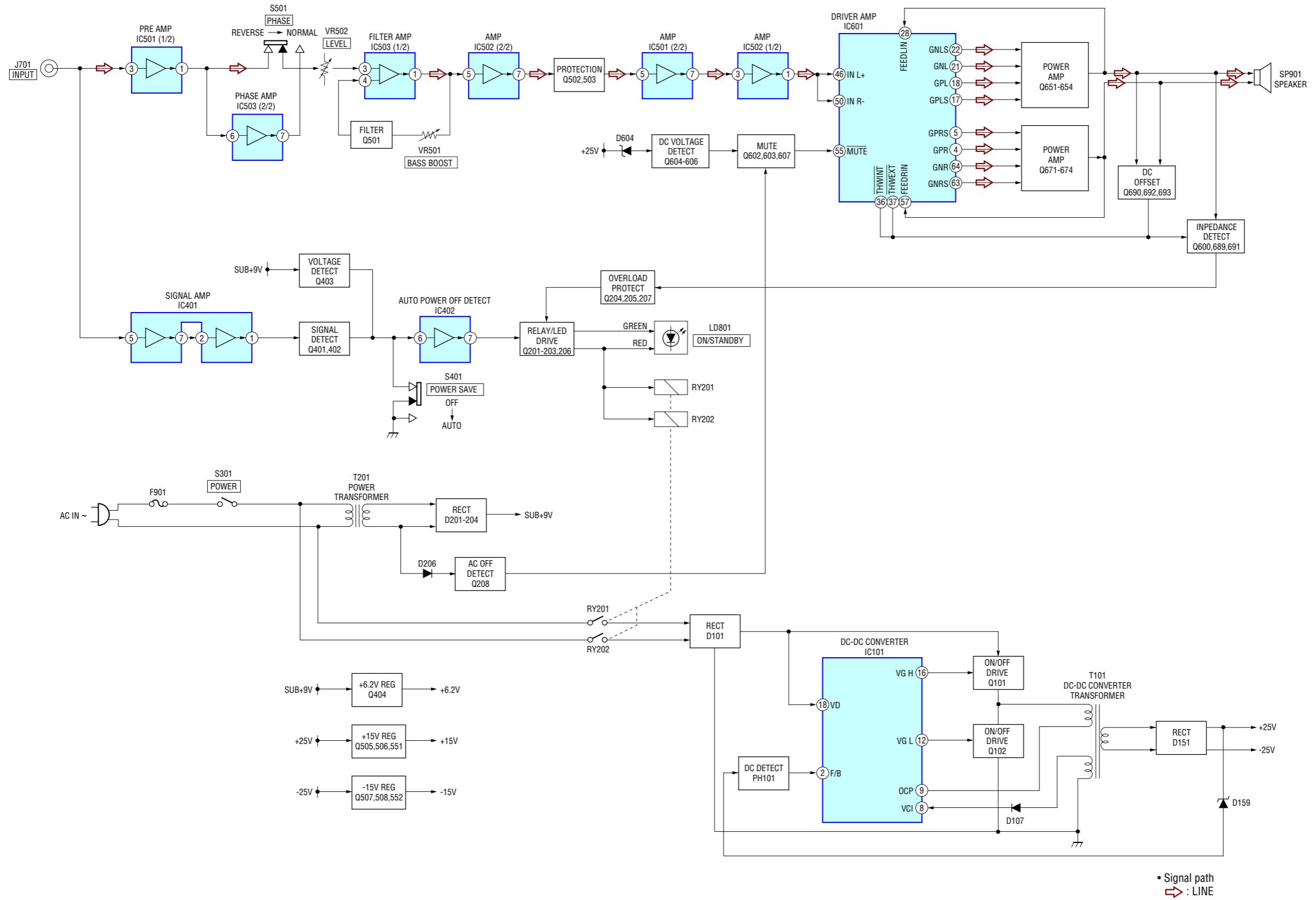

3-3. PRINTED WIRING BOARDS — FILTER SECTION — • Refer to page 10 for Circuit Boards Location.

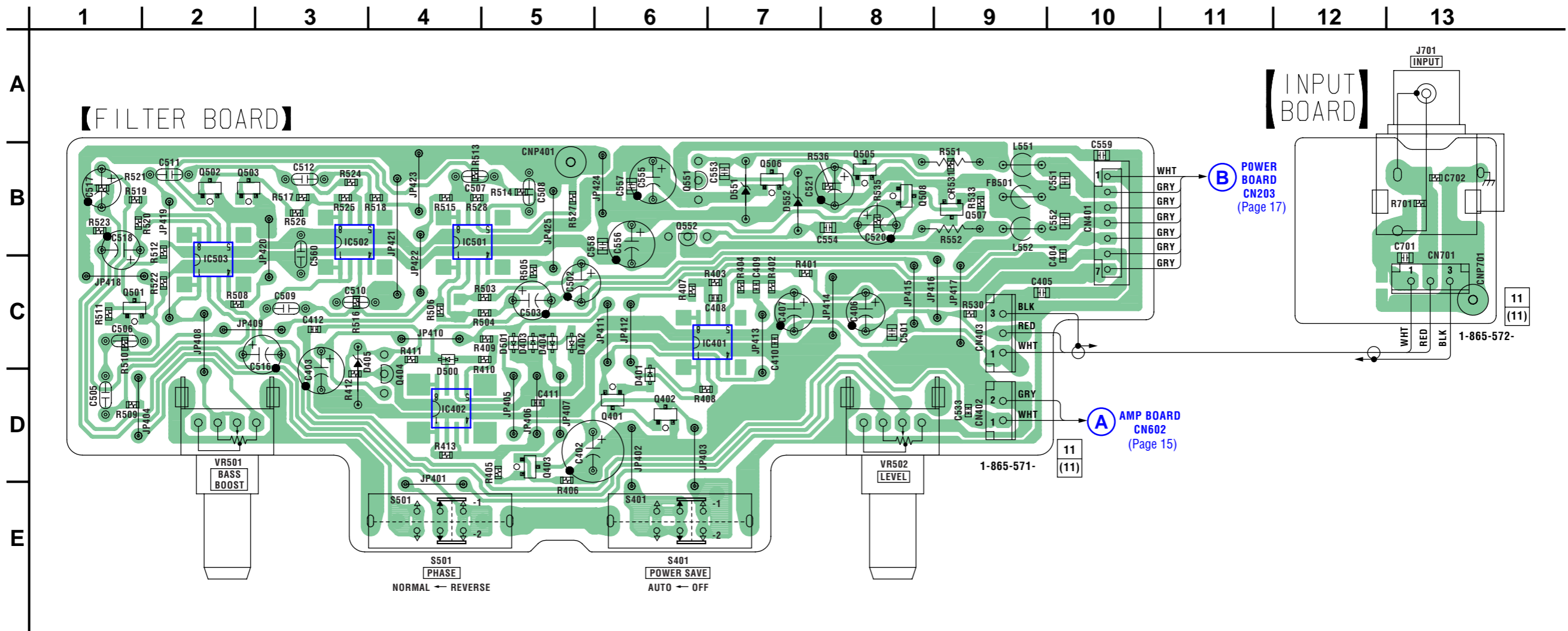

• Semiconductor Location

Ref. No.	Location
D401	D-6
D402	C-5
D403	C-5
D404	C-5
D405	C-3
D500	C-4
D501	C-5
D551	B-7
D552	B-7
IC401	C-7
IC402	D-4
IC501	B-4
IC502	B-3
IC503	C-2
Q401	D-6
Q402	D-6
Q403	D-5
Q404	D-4
Q501	C-1
Q502	B-2
Q503	B-2
Q505	B-8
Q506	B-7
Q507	B-9
Q508	B-8
Q551	B-6
Q552	B-6

3-4. SCHEMATIC DIAGRAM — FILTER SECTION —

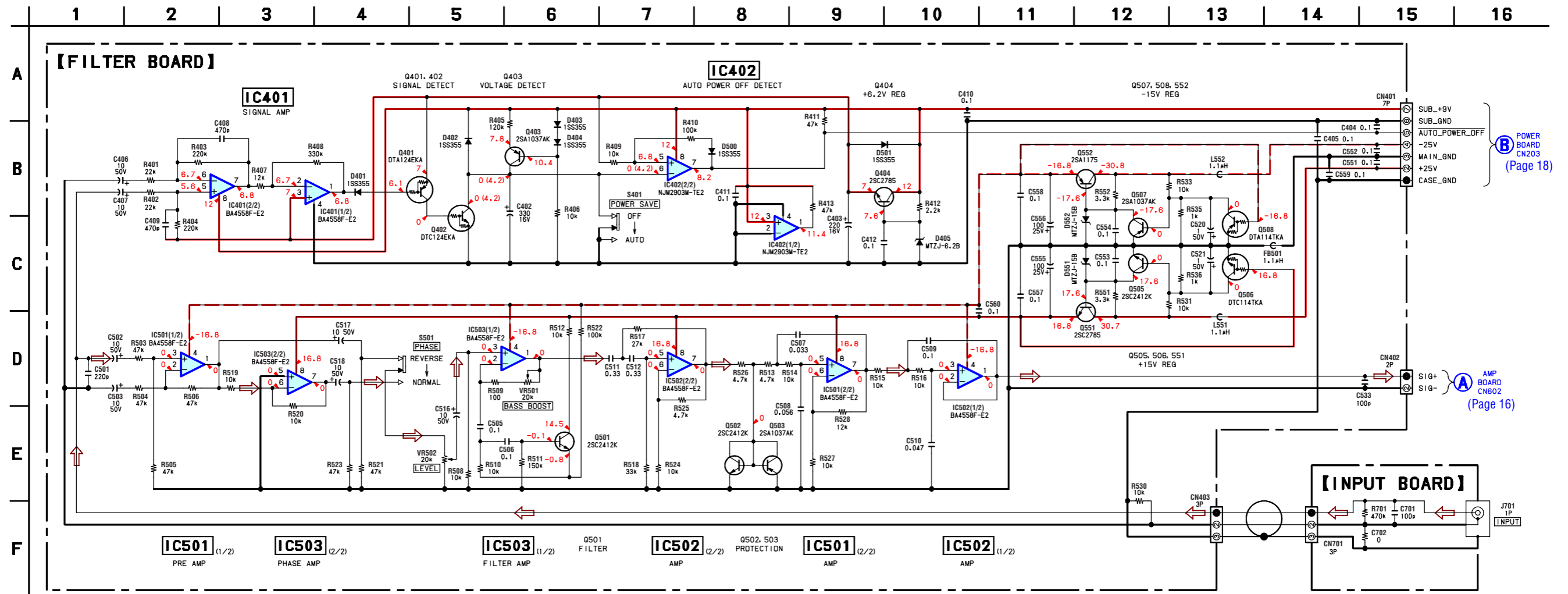

POWER BOARD CN203 (Page 18)

AMP BOARD CN602 (Page 16)

14 | 13 | 12 | 11 | 10 | 9 | 8 | 7 | 6 | 5 | 4 | 3 | 2 | 1

【AMP BOARD】(SIDE A)

• Semiconductor Location (Side A)

Ref. No.	Location
IC601	C-6
Q603	B-8
Q691	B-5

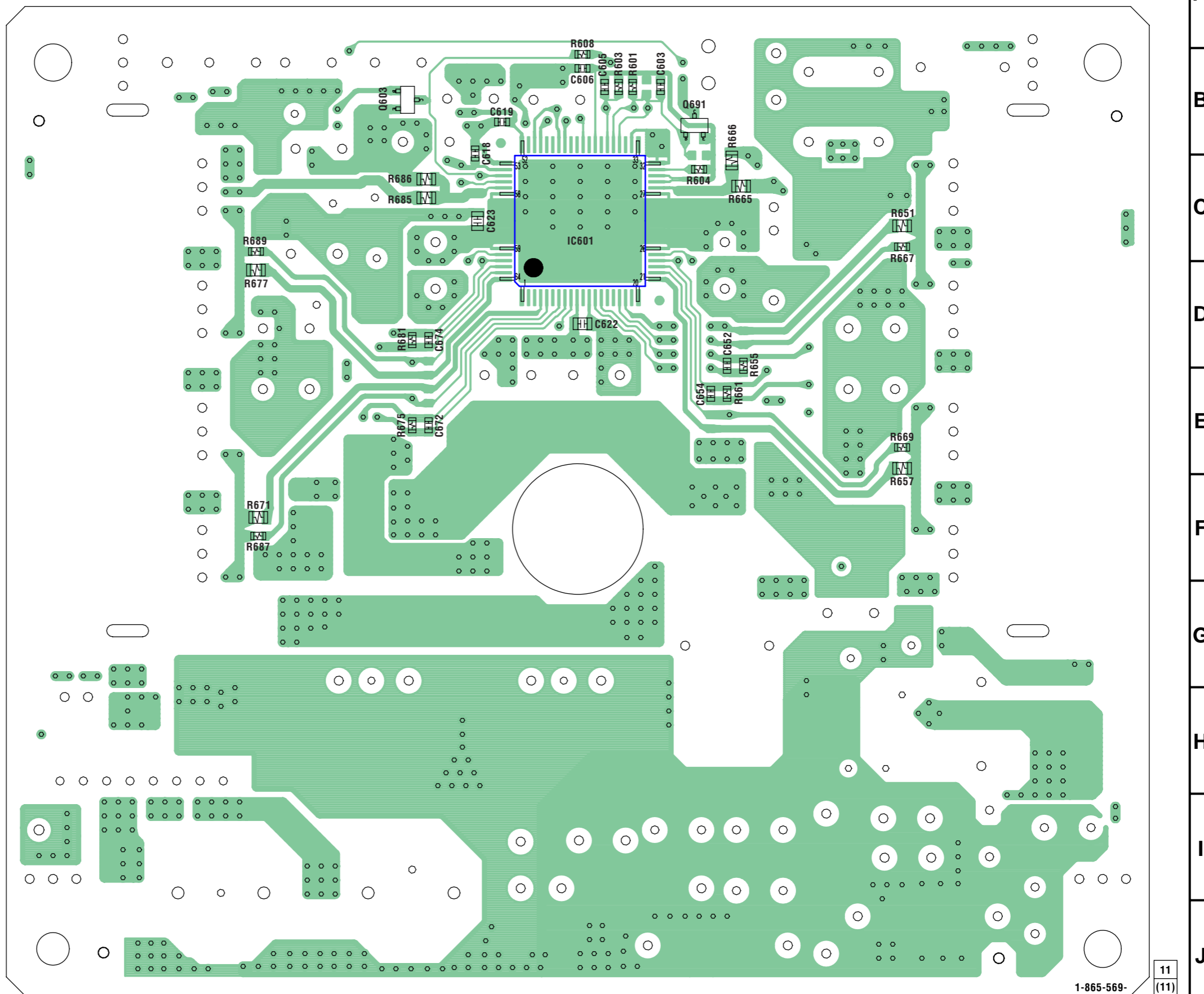

1-865-569-

11  
(11)

3-6. PRINTED WIRING BOARD — AMP SECTION (2/2) — • Refer to page 10 for Circuit Boards Location.

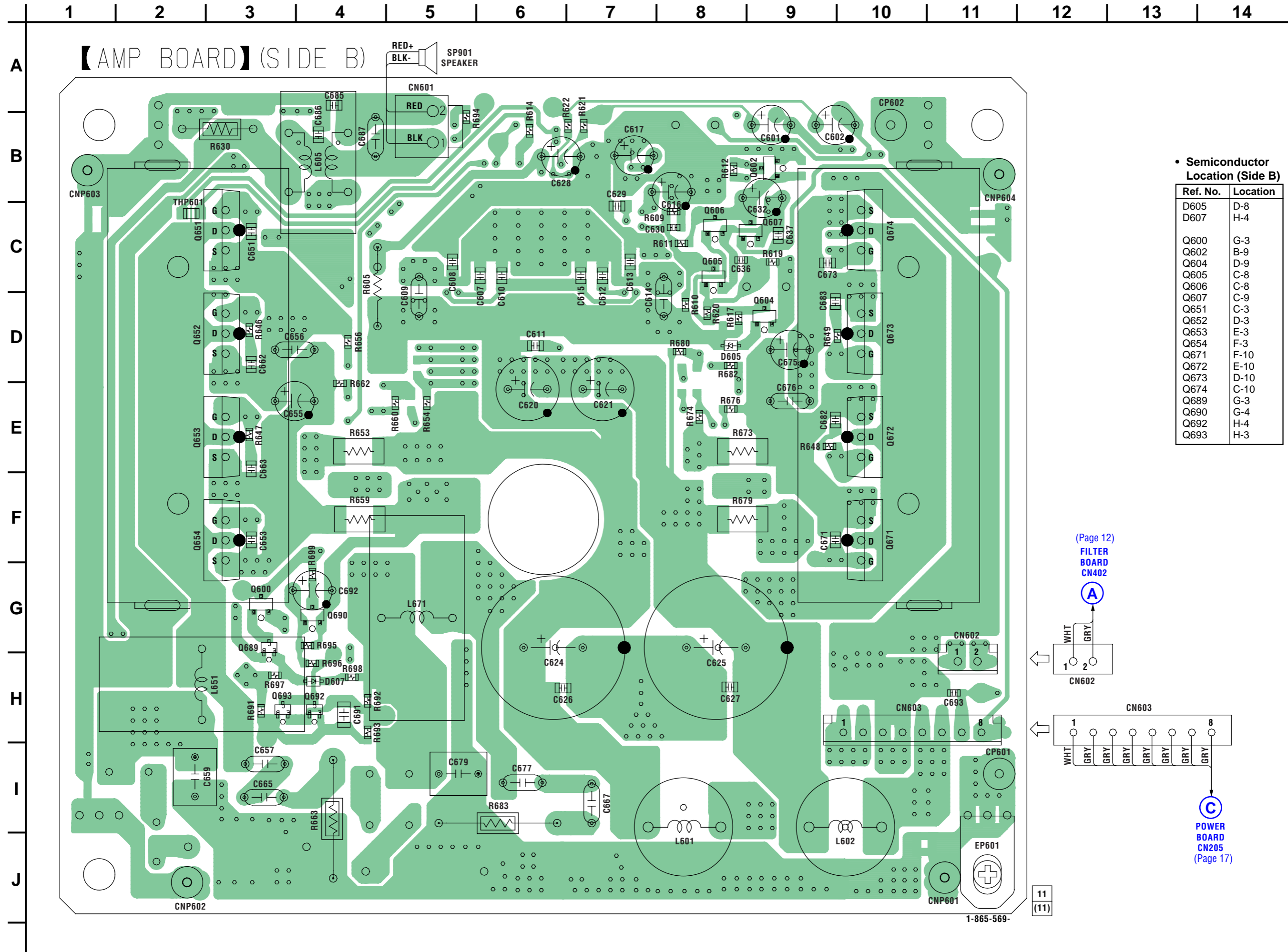

• Semiconductor Location (Side B)

Ref. No.	Location
D605	D-8
D607	H-4
Q600	G-3
Q602	B-9
Q604	D-9
Q605	C-8
Q606	C-8
Q607	C-9
Q651	C-3
Q652	D-3
Q653	E-3
Q654	F-3
Q671	F-10
Q672	E-10
Q673	D-10
Q674	C-10
Q689	G-3
Q690	G-4
Q692	H-4
Q693	H-3

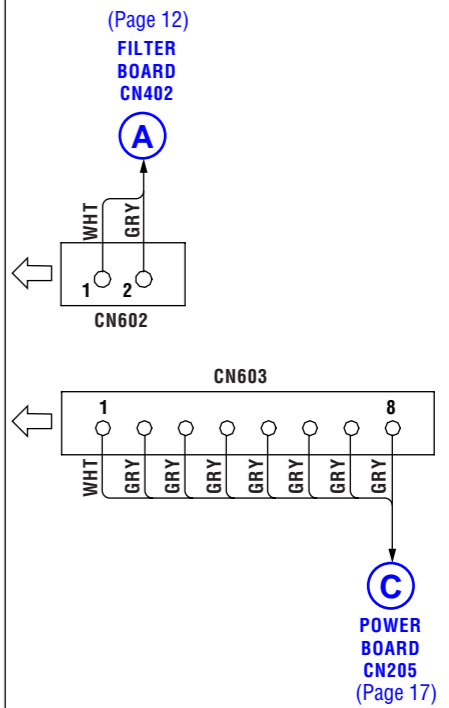

11  
(11)

3-7. SCHEMATIC DIAGRAM — AMP SECTION — • Refer to page 19 for IC Block Diagram.

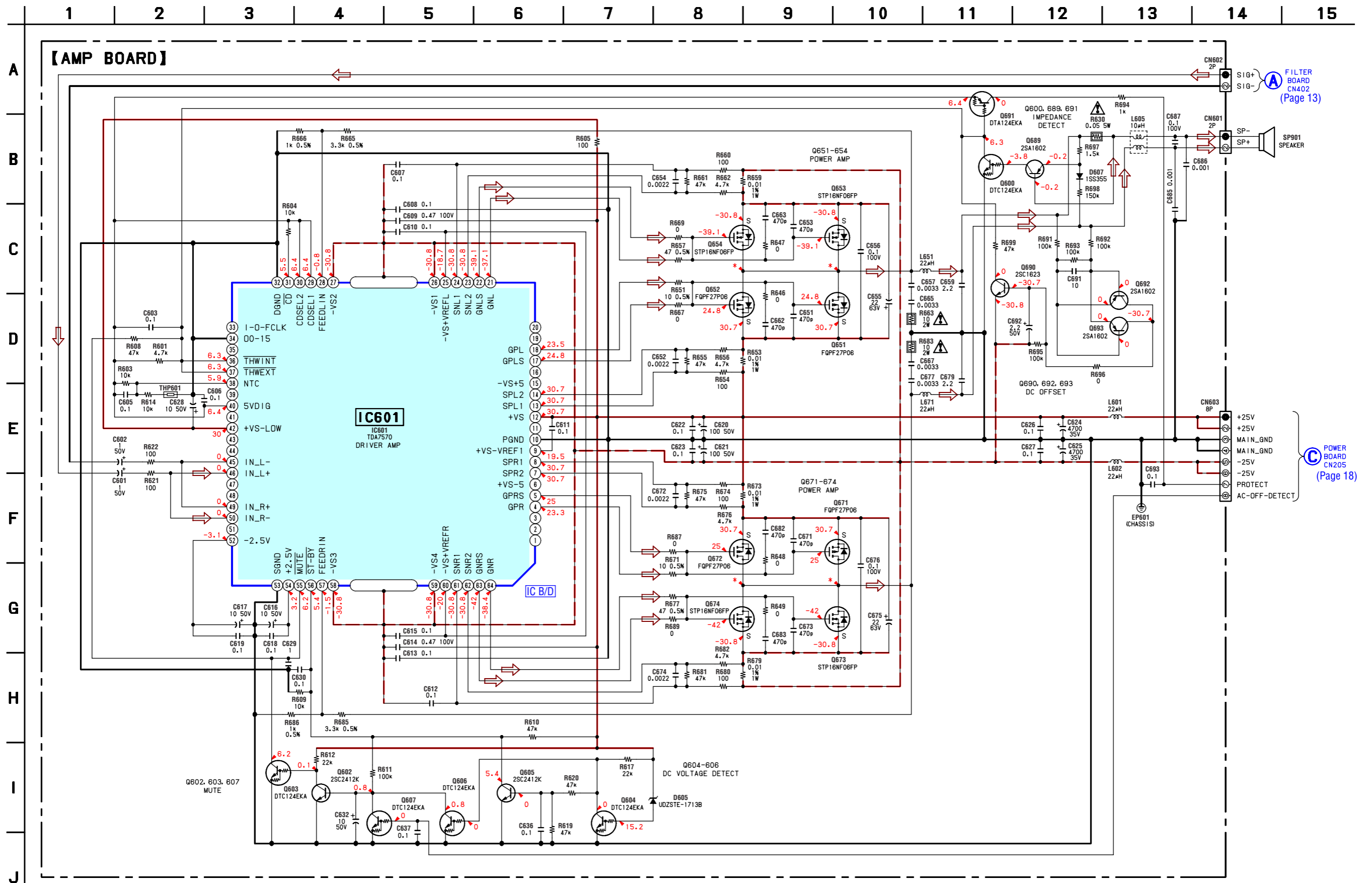



3-8. PRINTED WIRING BOARDS — POWER SECTION — • Refer to page 10 for Circuit Boards Location.

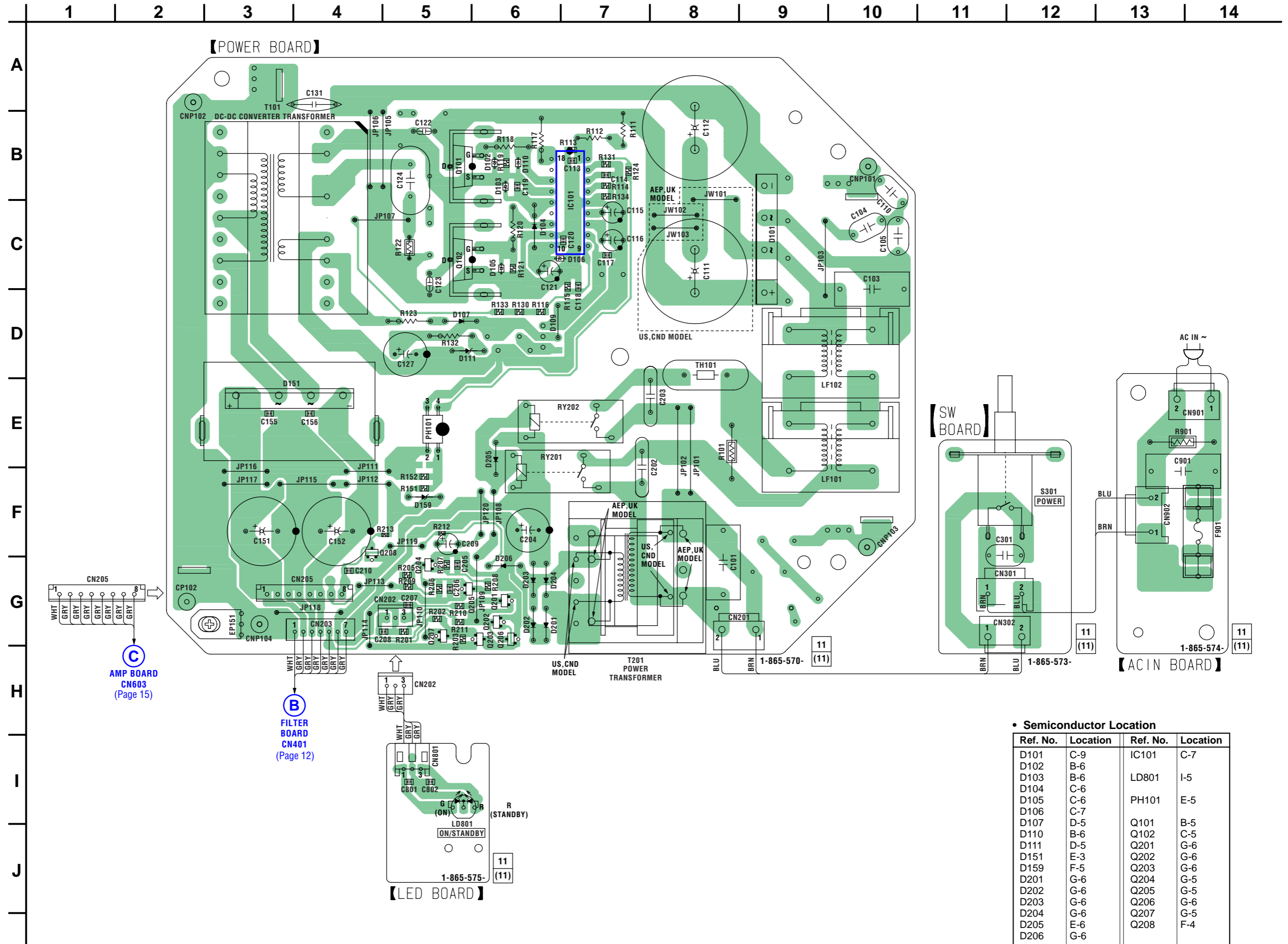

• Semiconductor Location

Ref. No.	Location	Ref. No.	Location
D101	C-9	IC101	C-7
D102	B-6	LD801	I-5
D103	B-6		
D104	C-6		
D105	C-6	PH101	E-5
D106	C-7		
D107	D-5	Q101	B-5
D110	B-6	Q102	C-5
D111	D-5	Q201	G-6
D151	E-3	Q202	G-6
D159	F-5	Q203	G-6
D201	G-6	Q204	G-5
D202	G-6	Q205	G-5
D203	G-6	Q206	G-6
D204	G-6	Q207	G-5
D205	E-6	Q208	F-4
D206	G-6		

3-9. SCHEMATIC DIAGRAM — POWER SECTION — • Refer to page 20 for IC Pin Description.

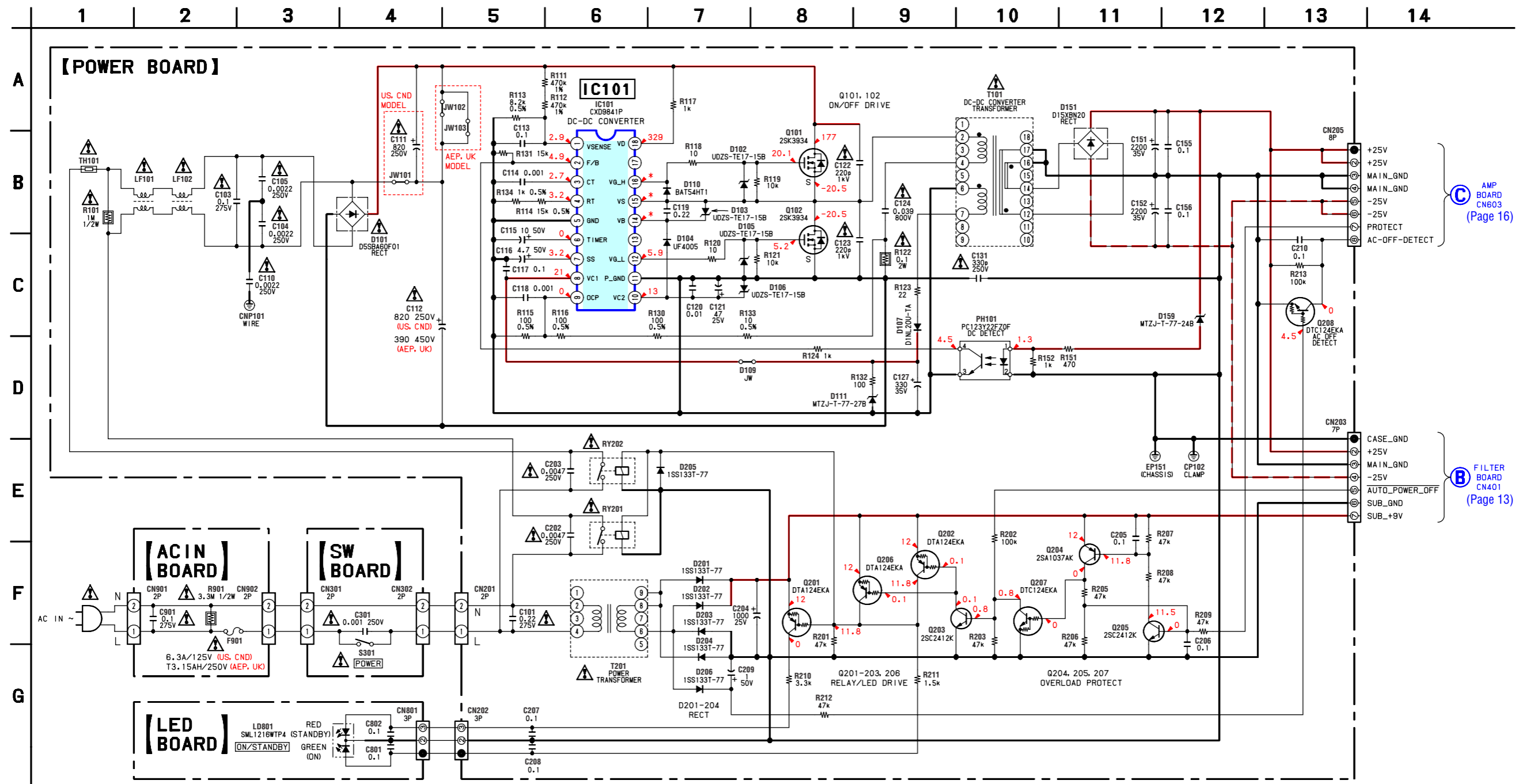

• IC Block Diagram

IC601 TDA7570 (AMP BOARD)

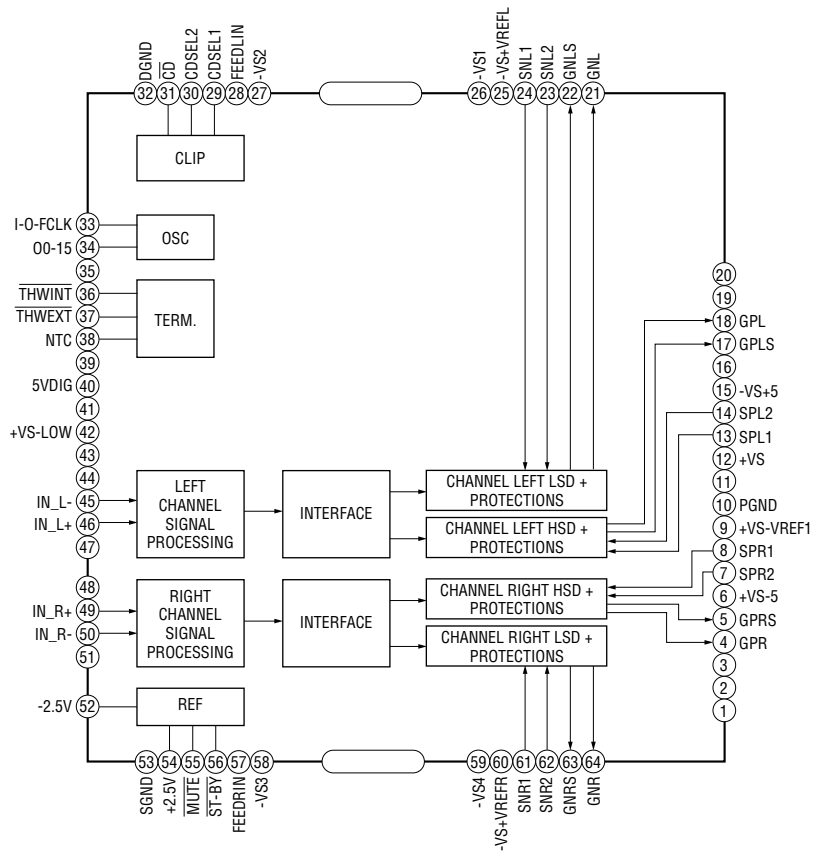

## • IC Pin Description

## IC101 CXD9841P (DC-DC CONVERTER) (POWER Board)

Pin No.	Pin Name	I/O	Pin Description
1	VSENSE	I	Terminal for detection of AC line voltage.
2	F/B	I	Terminal for frequency modulation with FB.
3	CT	I	Capacitor for oscillator.
4	RT	I	Oscillator frequency setting resistor
5	GND	—	Ground
6	TIMER	I	Capacitor determines the period of abnormal detection.
7	SS	I	Capacitor for a soft start timing.
8	VC1	I	Power supply terminal for the control circuit.
9	OCP	I	Terminal for over current detection and didt protection.
10	VC2	O	Power supply terminal for a driver.
11	P_GND	—	Ground for low side driver.
12	VG_L	O	Output of low side driver.
13	—	—	Not used. (Open)
14	VB	O	Power supply terminal for high side driver.
15	VS	I	Reference voltage terminal for high side driver.
16	VG_H	O	Output of high side driver.
17	—	—	Not used. (Open)
18	VD	I	Terminal for Drain-Kick starting.



4-2. CENTER SPEAKER SECTION  
(SS-CNF7ED)

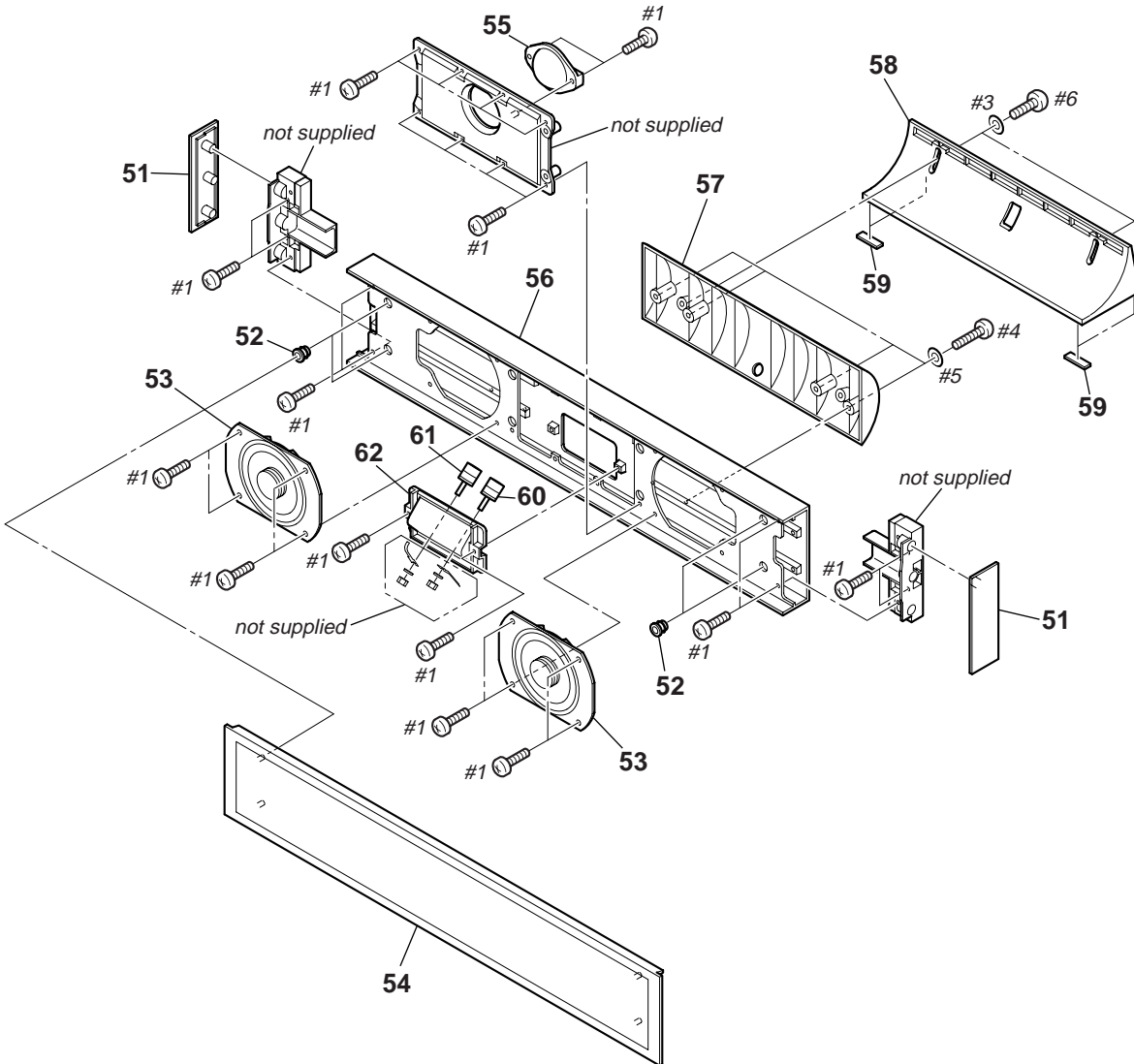

Ref. No.	Part No.	Description	Remark	Ref. No.	Part No.	Description	Remark
51	2-630-181-01	COVER, SIDE		60	1-780-292-21	TERMINAL (BLACK)	
52	4-235-399-01	CATCHER		61	1-780-292-11	TERMINAL (RED)	
53	1-826-121-11	LOUDSPEAKER (8cm)		62	2-630-184-01	TERMINAL BOARD (CN)	
54	A-1121-725-A	FRAME (CN) ASSY, GRILLE		#1	7-685-646-79	SCREW +BVTP 3X8 TYPE2 IT-3	
55	1-826-120-21	LOUDSPEAKER (2cm)		#3	7-623-926-11	WASHER 5.0, NYLON	
56	2-630-180-01	CABINET (CN)		#4	7-682-561-04	SCREW +B 4X8	
57	X-2059-327-1	BRACKET ASSY, BASE		#5	7-623-210-22	SW 4, TYPE 2	
58	2-630-306-01	BASE (CN)		#6	7-682-576-04	SCREW +B 5X12	
59	2-630-307-01	FOOT (CN)					

4-3. SPEAKER STAND SECTION  
(WS-FT7)

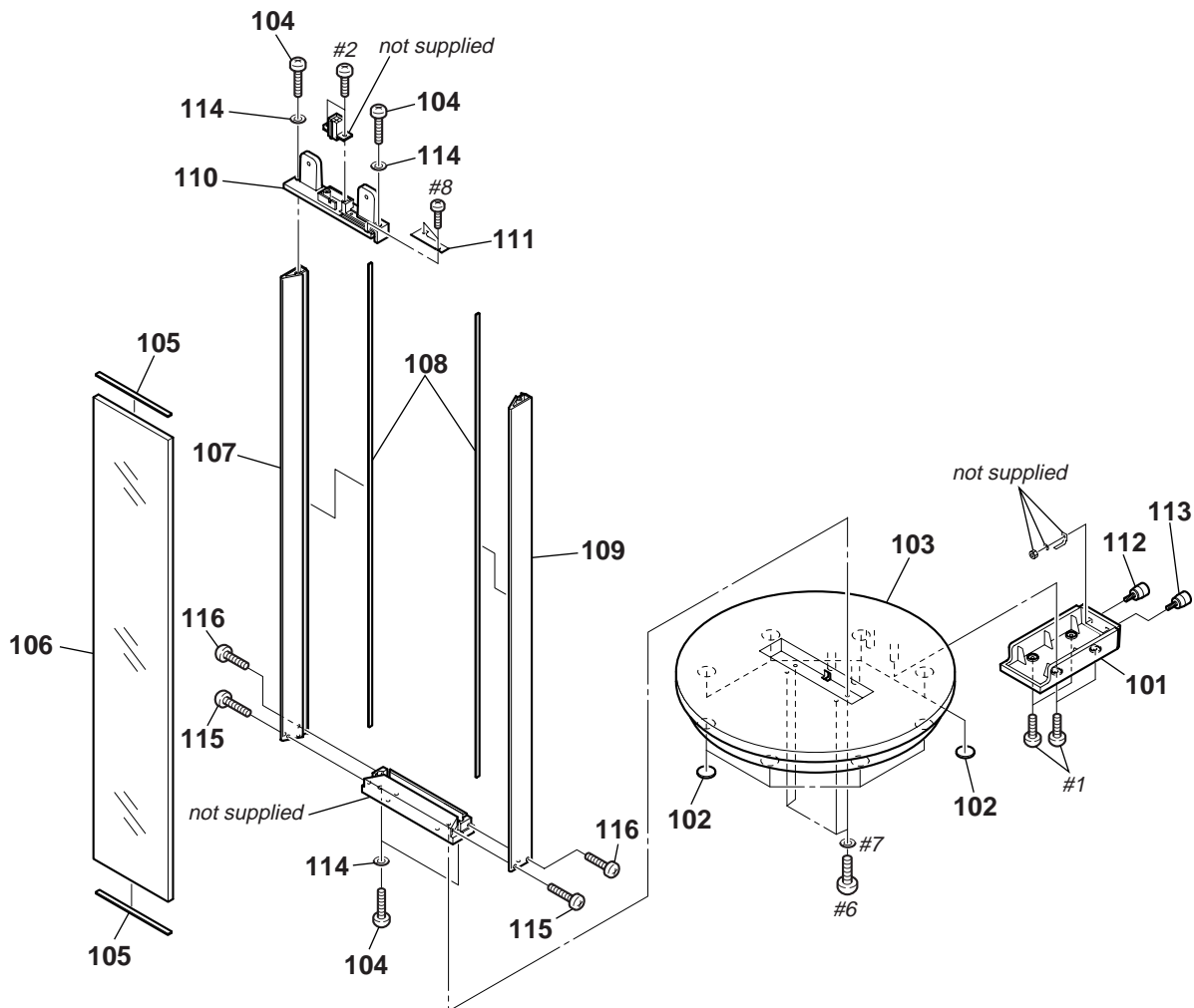

Ref. No.	Part No.	Description	Remark	Ref. No.	Part No.	Description	Remark
101	2-630-207-01	TERMINAL BOARD (FR)		112	1-780-292-11	TERMINAL (RED)	
102	2-630-208-01	FOOT (FR)		113	1-780-292-21	TERMINAL (BLACK)	
103	2-630-206-01	BASE (FR)		114	9-885-094-64	SW 3.5, TYPE2	
104	4-986-971-01	SCREW (3.5)		115	9-885-094-65	SCREW +KTP 3.5X14 TYPE2 IT-3	
105	2-630-211-01	PACKING (H), GLASS		116	9-885-094-66	SCREW +KTP 3.5X8 TYPE2 IT-3	
106	2-630-204-01	GLASS		#1	7-685-646-79	SCREW +BVTP 3X8 TYPE2 IT-3	
107	2-630-203-01	STAY (L)		#2	7-685-648-79	SCREW +BVTP 3X12 TYPE2 IT-3	
108	2-630-210-01	PACKING (V), GLASS		#6	7-682-576-04	SCREW +B 5X12	
109	2-630-202-01	STAY (R)		#7	7-623-212-22	SW 5, TYPE2	
110	2-630-205-01	JOINT (ST)		#8	7-621-775-10	SCREW +B 2.6X4	
111	2-630-201-01	HOLDER, CORD					

4-4. SUBWOOFER SECTION (1)  
(SA-WFT7)

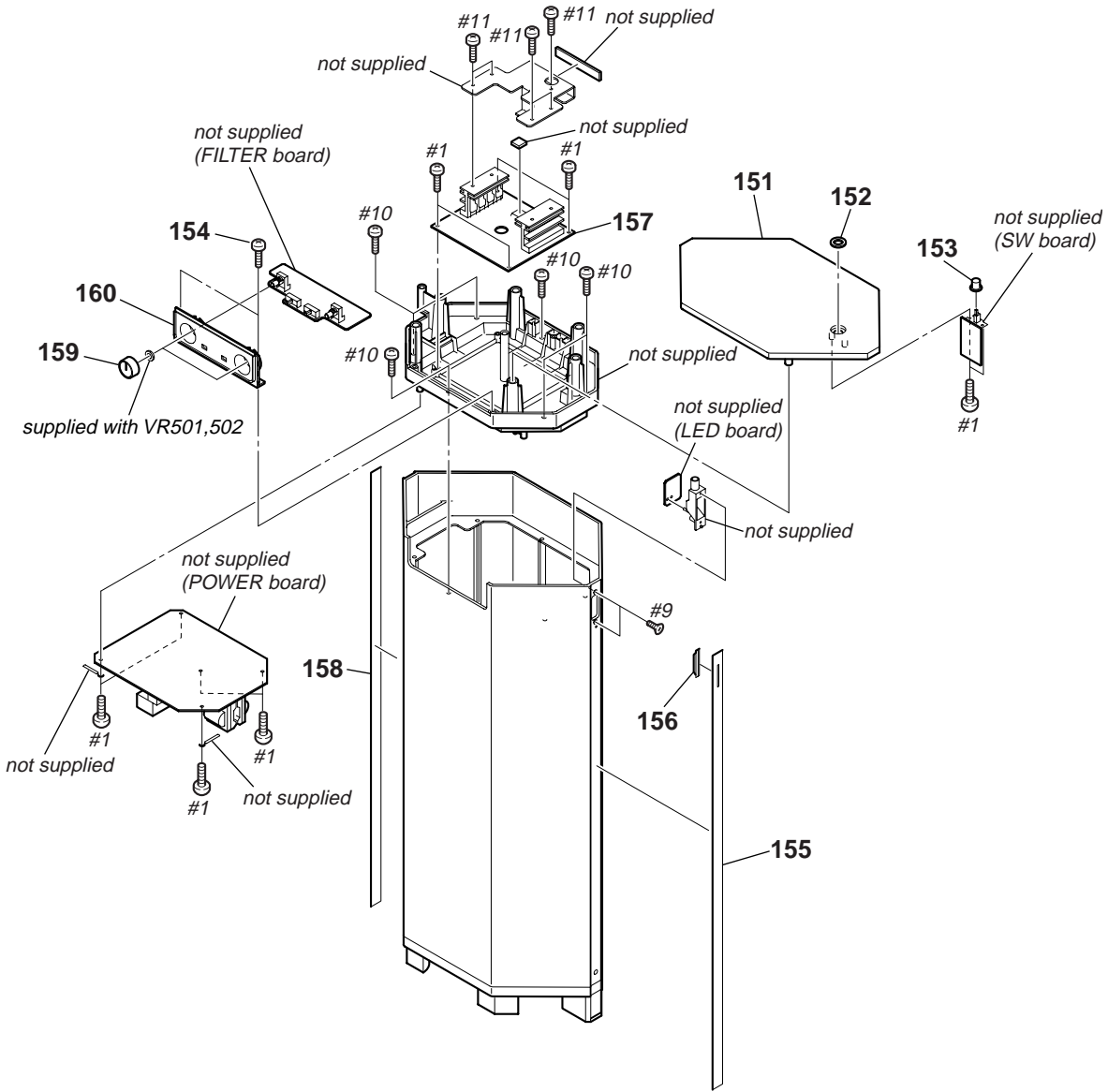

Ref. No.	Part No.	Description	Remark	Ref. No.	Part No.	Description	Remark
151	2-630-123-01	COVER, TOP (AEP,UK)		158	2-630-159-01	PANEL (RR), ORNAMENTAL	
151	2-630-123-11	COVER, TOP (US,CND)		159	2-630-127-01	KNOB (VOL)	
152	2-630-124-01	RING, ORNAMENTAL		160	2-630-126-01	PANEL, CONTROL	
153	2-630-125-01	KNOB, PUSH		#1	7-685-646-79	SCREW +BVTP 3X8 TYPE2 IT-3	
154	4-874-614-12	SCREW (1) (3.5X14), TAPPING		#9	7-685-235-19	SCREW +KTP 2.6X10 TYPE2 NON-SLIT	
155	2-630-158-01	PANEL (FR), ORNAMENTAL		#10	7-685-663-79	SCREW +BVTP 4X16 TYPE2 IT-3	
156	2-630-131-01	INDICATOR		#11	7-685-645-79	SCREW +BVTP 3X6 TYPE2 IT-3	
157	A-1119-253-A	AMP BOARD, COMPLETE					



4-5. SUBWOOFER SECTION (2)  
(SA-WFT7)

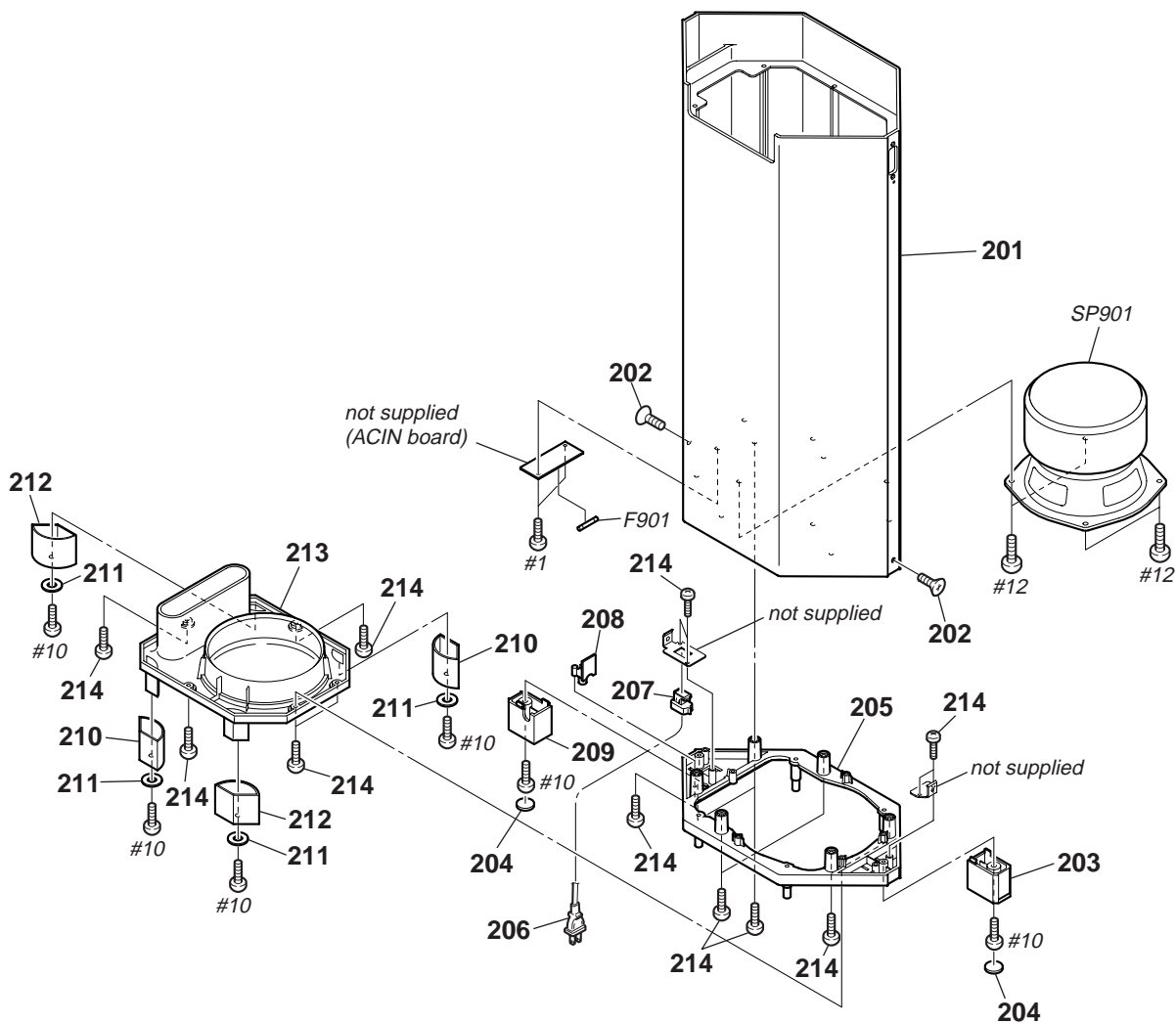

Ref. No.	Part No.	Description	Remark	Ref. No.	Part No.	Description	Remark
201	A-1119-012-A	CABINET ASSY, SPEAKER		210	2-630-154-01	COVER (A), FOOT	
202	9-885-094-67	SCREW +KTP 3.5X12 TYPE2 IT-3		211	2-630-156-01	PAD (A), FOOT	
203	2-630-139-01	FOOT (FR)		212	2-630-155-01	COVER (B), FOOT	
204	2-630-157-01	PAD (B), FOOT		213	X-2055-998-1	COVER (B) ASSY, BOTTOM (AEP,UK)	
205	2-630-136-01	COVER (A), BOTTOM (AEP,UK)		213	X-2102-649-1	COVER (B) ASSY, BOTTOM (US,CND)	
206	2-630-136-11	COVER (A), BOTTOM (US,CND)		214	4-874-614-12	SCREW (1) (3.5X14), TAPPING	
△206	1-751-528-11	CORD, POWER (UK)		△F901	1-576-230-51	FUSE (T3.15AH/250V) (AEP,UK)	
△206	1-769-744-52	CORD, POWER (AEP)		△F901	1-576-233-51	FUSE (6.3A/250V) (US,CND)	
△206	1-783-531-12	CORD, POWER (US,CND)		SP901	1-826-122-11	LOUDSPEAKER (15cm)	
207	3-703-244-00	BUSHING (2104), CORD		#1	7-685-646-79	SCREW +BVTP 3X8 TYPE2 IT-3	
208	A-1119-249-A	INPUT BOARD, COMPLETE		#10	7-685-663-79	SCREW +BVTP 4X16 TYPE2 IT-3	
209	2-630-140-01	FOOT (RR)		#12	7-682-577-04	SCREW +B 5X14	

4-6. BRACKET, BASE SECTION

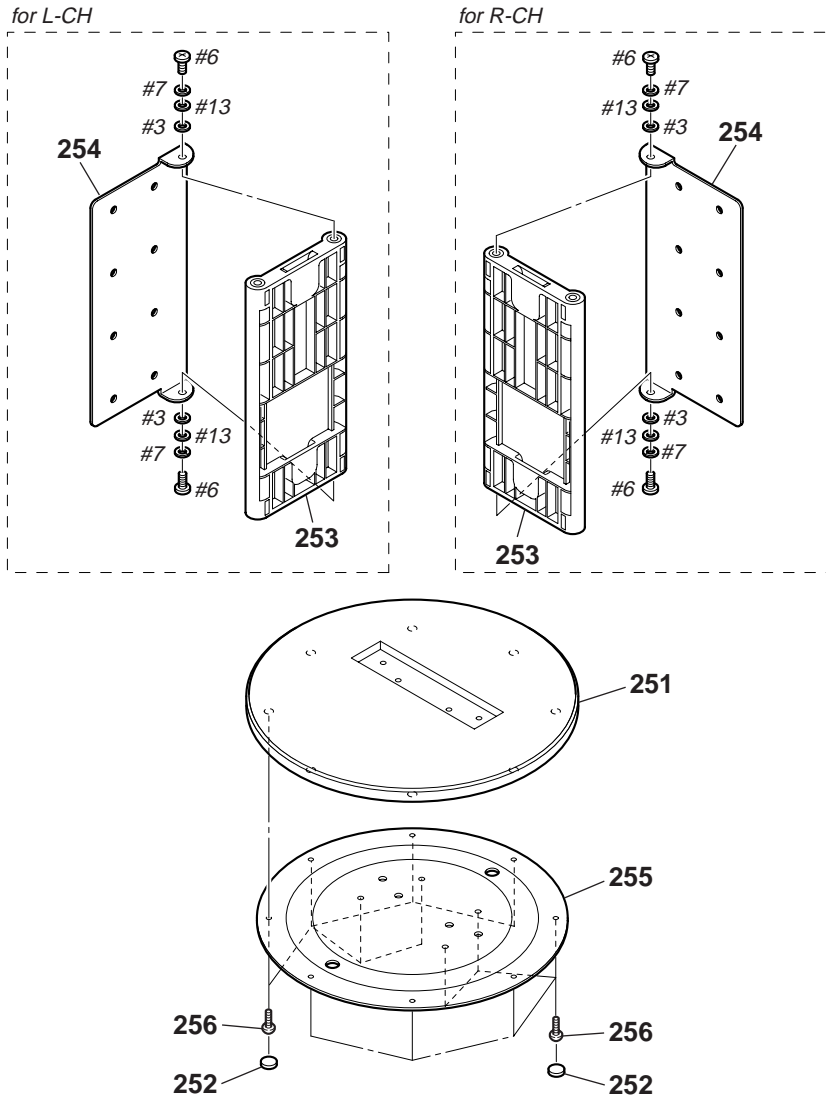

Ref. No.	Part No.	Description	Remark	Ref. No.	Part No.	Description	Remark
251	2-630-299-01	BASE (DT)		256	4-986-971-01	SCREW (3.5)	
252	2-630-300-01	FOOT (DT)		#3	7-623-926-11	WASHER 5.0, NYLON	
253	X-2059-451-1	BRACKET (FR) ASSY		#6	7-682-576-04	SCREW +B 5X12	
254	2-630-256-01	BRACKET		#7	7-623-212-22	SW 5, TYPE2	
255	2-636-583-01	PLATE (DT), BOTTOM		#13	7-688-005-01	W 5, SMALL	

## SECTION 5

## ELECTRICAL PARTS LIST

ACIN AMP

## NOTE:

- Due to standardization, replacements in the parts list may be different from the parts specified in the diagrams or the components used on the set.
- -XX and -X mean standardized parts, so they may have some difference from the original one.
- RESISTORS  
All resistors are in ohms.  
METAL: Metal-film resistor.  
METAL OXIDE: Metal oxide-film resistor.  
F: nonflammable
- Abbreviation  
CND : Canadian model

- Items marked “\*” are not stocked since they are seldom required for routine service. Some delay should be anticipated when ordering these items.
- SEMICONDUCTORS  
In each case, u :  $\mu$ , for example:  
uA.. :  $\mu$ A.. uPA.. :  $\mu$ PA..  
uPB.. :  $\mu$ PB.. uPC.. :  $\mu$ PC.. uPD.. :  $\mu$ PD..
- CAPACITORS  
uF :  $\mu$ F
- COILS  
uH :  $\mu$ H

The components identified by mark  $\triangle$  or dotted line with mark  $\triangle$  are critical for safety. Replace only with part number specified.

Les composants identifiés par une marque  $\triangle$  sont critiques pour la sécurité. Ne les remplacer que par une pièce portant le numéro spécifié.

When indicating parts by reference number, please include the board.

Ref. No.	Part No.	Description	Remark	Ref. No.	Part No.	Description	Remark
		ACIN BOARD *****		C625	1-107-900-51	ELECT 4700uF 20%	35V
				C626	1-165-319-11	CERAMIC CHIP 0.1uF	50V
				C627	1-165-319-11	CERAMIC CHIP 0.1uF	50V
	1-533-313-11	HOLDER, FUSE		C628	1-126-964-11	ELECT 10uF 20%	50V
		< CAPACITOR >		C629	1-164-346-11	CERAMIC CHIP 1uF	16V
$\triangle$ C901	1-165-528-11	MYLAR 0.1uF 10%	275V	C630	1-164-156-11	CERAMIC CHIP 0.1uF	25V
		< CONNECTOR >		C632	1-126-964-11	ELECT 10uF 20%	50V
CN901	1-564-321-00	PIN, CONNECTOR (3.96mm PITCH) 2P		C636	1-164-156-11	CERAMIC CHIP 0.1uF	25V
* CN902	1-580-230-11	PIN, CONNECTOR (PC BOARD) 2P		C637	1-165-319-11	CERAMIC CHIP 0.1uF	50V
		< RESISTOR >		C651	1-163-005-11	CERAMIC CHIP 470PF 10%	50V
$\triangle$ R901	1-219-237-11	SOLID 3.3M 20%	1/2W F	C652	1-162-966-11	CERAMIC CHIP 0.0022uF 10%	50V
		*****		C653	1-163-005-11	CERAMIC CHIP 470PF 10%	50V
	A-1119-253-A	AMP BOARD, COMPLETE *****		C654	1-162-966-11	CERAMIC CHIP 0.0022uF 10%	50V
	4-931-757-31	SCREW (DIA.2.6X8) (IT3B), TAPPING		C655	1-128-551-11	ELECT 22uF 20%	63V
		< CAPACITOR >		C656	1-130-777-00	MYLAR 0.1uF 5%	100V
C601	1-126-960-11	ELECT 1uF 20%	50V	C657	1-130-477-00	MYLAR 0.0033uF 5%	50V
C602	1-126-960-11	ELECT 1uF 20%	50V	C659	1-135-621-51	FILM 2.2uF 5%	50V
C603	1-164-156-11	CERAMIC CHIP 0.1uF	25V	C662	1-163-005-11	CERAMIC CHIP 470PF 10%	50V
C605	1-164-156-11	CERAMIC CHIP 0.1uF	25V	C663	1-163-005-11	CERAMIC CHIP 470PF 10%	50V
C606	1-164-156-11	CERAMIC CHIP 0.1uF	25V	C665	1-130-477-00	MYLAR 0.0033uF 5%	50V
C607	1-165-319-11	CERAMIC CHIP 0.1uF	50V	C667	1-130-477-00	MYLAR 0.0033uF 5%	50V
C608	1-165-319-11	CERAMIC CHIP 0.1uF	50V	C671	1-163-005-11	CERAMIC CHIP 470PF 10%	50V
C609	1-137-959-11	MYLAR 0.47uF 5%	100V	C672	1-162-966-11	CERAMIC CHIP 0.0022uF 10%	50V
C610	1-165-319-11	CERAMIC CHIP 0.1uF	50V	C673	1-163-005-11	CERAMIC CHIP 470PF 10%	50V
C611	1-165-319-11	CERAMIC CHIP 0.1uF	50V	C674	1-162-966-11	CERAMIC CHIP 0.0022uF 10%	50V
C612	1-165-319-11	CERAMIC CHIP 0.1uF	50V	C675	1-128-551-11	ELECT 22uF 20%	63V
C613	1-165-319-11	CERAMIC CHIP 0.1uF	50V	C676	1-130-777-00	MYLAR 0.1uF 5%	100V
C614	1-137-959-11	MYLAR 0.47uF 5%	100V	C677	1-130-477-00	MYLAR 0.0033uF 5%	50V
C615	1-165-319-11	CERAMIC CHIP 0.1uF	50V	C679	1-135-621-51	FILM 2.2uF 5%	50V
C616	1-126-964-11	ELECT 10uF 20%	50V	C682	1-163-005-11	CERAMIC CHIP 470PF 10%	50V
C617	1-126-964-11	ELECT 10uF 20%	50V	C683	1-163-005-11	CERAMIC CHIP 470PF 10%	50V
C618	1-164-156-11	CERAMIC CHIP 0.1uF	25V	C685	1-163-009-11	CERAMIC CHIP 0.001uF 10%	50V
C619	1-164-156-11	CERAMIC CHIP 0.1uF	25V	C686	1-163-009-11	CERAMIC CHIP 0.001uF 10%	50V
C620	1-126-968-11	ELECT 100uF 20%	50V	C687	1-130-777-00	MYLAR 0.1uF 5%	100V
C621	1-126-968-11	ELECT 100uF 20%	50V	C691	1-117-370-11	CERAMIC CHIP 10uF	10V
C622	1-165-319-11	CERAMIC CHIP 0.1uF	50V	C692	1-126-961-11	ELECT 2.2uF 20%	50V
C623	1-165-319-11	CERAMIC CHIP 0.1uF	50V	C693	1-164-156-11	CERAMIC CHIP 0.1uF	25V
C624	1-107-900-51	ELECT 4700uF 20%	35V			< CONNECTOR >	
				CN601	1-564-320-00	PIN, CONNECTOR (3.96mm PITCH) 2P	
				CN602	1-564-505-11	PLUG, CONNECTOR 2P	
				* CN603	1-564-511-11	PLUG, CONNECTOR 8P	

SA-FT7ED/WFT7/SS-CNF7ED/FRF7ED/WS-FT7

AMP FILTER

Ref. No.	Part No.	Description	Remark
		< DIODE >	
D605	8-719-083-63	DIODE UDZSTE-1713B	
D607	8-719-988-61	DIODE 1SS355TE-17	
		< GROUND TERMINAL >	
EP601	1-537-770-21	TERMINAL BOARD, GROUND	
		< IC >	
IC601	6-708-086-01	IC TDA7570	
		< COIL >	
L601	1-400-242-11	INDUCTOR 22uH	
L602	1-400-242-11	INDUCTOR 22uH	
L605	1-457-137-11	COIL, CHOKE 10uH	
L651	1-457-100-11	INDUCTOR 22uH	
L671	1-457-100-11	INDUCTOR 22uH	
		< TRANSISTOR >	
Q600	8-729-901-00	TRANSISTOR DTC124EK	
Q602	8-729-120-28	TRANSISTOR 2SC1623-L5L6	
Q603	8-729-901-00	TRANSISTOR DTC124EK	
Q604	8-729-901-00	TRANSISTOR DTC124EK	
Q605	8-729-120-28	TRANSISTOR 2SC1623-L5L6	
Q606	8-729-901-00	TRANSISTOR DTC124EK	
Q607	8-729-901-00	TRANSISTOR DTC124EK	
Q651	6-551-313-01	FET FQPF27P06	
Q652	6-551-313-01	FET FQPF27P06	
Q653	6-551-309-01	FET STP16NF06FP	
Q654	6-551-309-01	FET STP16NF06FP	
Q671	6-551-313-01	FET FQPF27P06	
Q672	6-551-313-01	FET FQPF27P06	
Q673	6-551-309-01	FET STP16NF06FP	
Q674	6-551-309-01	FET STP16NF06FP	
Q689	8-729-602-36	TRANSISTOR 2SA1602-F	
Q690	8-729-120-28	TRANSISTOR 2SC1623-L5L6	
Q691	8-729-027-31	TRANSISTOR DTA124EKA-T146	
Q692	8-729-602-36	TRANSISTOR 2SA1602-F	
Q693	8-729-602-36	TRANSISTOR 2SA1602-F	
		< RESISTOR >	
R601	1-216-829-11	METAL CHIP 4.7K 5%	1/10W
R603	1-216-833-11	METAL CHIP 10K 5%	1/10W
R604	1-216-833-11	METAL CHIP 10K 5%	1/10W
R605	1-249-899-11	CARBON 100 1%	1/4W
R608	1-216-841-11	METAL CHIP 47K 5%	1/10W
R609	1-216-833-11	METAL CHIP 10K 5%	1/10W
R610	1-216-841-11	METAL CHIP 47K 5%	1/10W
R611	1-216-845-11	METAL CHIP 100K 5%	1/10W
R612	1-216-837-11	METAL CHIP 22K 5%	1/10W
R614	1-216-833-11	METAL CHIP 10K 5%	1/10W
R617	1-216-837-11	METAL CHIP 22K 5%	1/10W
R619	1-216-841-11	METAL CHIP 47K 5%	1/10W
R620	1-216-841-11	METAL CHIP 47K 5%	1/10W
R621	1-216-809-11	METAL CHIP 100 5%	1/10W
R622	1-216-809-11	METAL CHIP 100 5%	1/10W
△R630	1-243-665-11	METAL 0.05 5%	5W F
R646	1-216-864-11	SHORT CHIP 0	

Ref. No.	Part No.	Description	Remark
R647	1-216-864-11	SHORT CHIP 0	
R648	1-216-864-11	SHORT CHIP 0	
R649	1-216-864-11	SHORT CHIP 0	
R651	1-216-603-11	METAL CHIP 10 0.5%	1/10W
R653	1-219-684-11	RES-CHIP 0.01 1%	1W
R654	1-216-809-11	METAL CHIP 100 5%	1/10W
R655	1-216-841-11	METAL CHIP 47K 5%	1/10W
R656	1-216-829-11	METAL CHIP 4.7K 5%	1/10W
R657	1-216-619-11	METAL CHIP 47 0.5%	1/10W
R659	1-219-684-11	RES-CHIP 0.01 1%	1W
R660	1-216-809-11	METAL CHIP 100 5%	1/10W
R661	1-216-841-11	METAL CHIP 47K 5%	1/10W
R662	1-216-829-11	METAL CHIP 4.7K 5%	1/10W
△R663	1-215-880-00	METAL OXIDE 10 5%	2W F
R665	1-216-663-11	METAL CHIP 3.3K 0.5%	1/10W
R666	1-216-651-11	METAL CHIP 1K 0.5%	1/10W
R667	1-216-864-11	SHORT CHIP 0	
R669	1-216-864-11	SHORT CHIP 0	
R671	1-216-603-11	METAL CHIP 10 0.5%	1/10W
R673	1-219-684-11	RES-CHIP 0.01 1%	1W
R674	1-216-809-11	METAL CHIP 100 5%	1/10W
R675	1-216-841-11	METAL CHIP 47K 5%	1/10W
R676	1-216-829-11	METAL CHIP 4.7K 5%	1/10W
R677	1-216-619-11	METAL CHIP 47 0.5%	1/10W
R679	1-219-684-11	RES-CHIP 0.01 1%	1W
R680	1-216-809-11	METAL CHIP 100 5%	1/10W
R681	1-216-841-11	METAL CHIP 47K 5%	1/10W
R682	1-216-829-11	METAL CHIP 4.7K 5%	1/10W
△R683	1-215-880-00	METAL OXIDE 10 5%	2W F
R685	1-216-663-11	METAL CHIP 3.3K 0.5%	1/10W
R686	1-216-651-11	METAL CHIP 1K 0.5%	1/10W
R687	1-216-864-11	SHORT CHIP 0	
R689	1-216-864-11	SHORT CHIP 0	
R691	1-216-845-11	METAL CHIP 100K 5%	1/10W
R692	1-216-845-11	METAL CHIP 100K 5%	1/10W
R693	1-216-845-11	METAL CHIP 100K 5%	1/10W
R694	1-216-821-11	METAL CHIP 1K 5%	1/10W
R695	1-216-845-11	METAL CHIP 100K 5%	1/10W
R696	1-216-864-11	SHORT CHIP 0	
R697	1-216-823-11	METAL CHIP 1.5K 5%	1/10W
R698	1-216-847-11	METAL CHIP 150K 5%	1/10W
R699	1-216-841-11	METAL CHIP 47K 5%	1/10W
		< THERMISTOR (POSITIVE) >	
THP601	1-804-301-11	THERMISTOR, CHIP	
*****			
		FILTER BOARD	
		*****	
		< CAPACITOR >	
C402	1-104-661-11	ELECT 330uF 20%	16V
C403	1-126-934-11	ELECT 220uF 20%	16V
C404	1-164-156-11	CERAMIC CHIP 0.1uF	25V
C405	1-164-156-11	CERAMIC CHIP 0.1uF	25V
C406	1-126-964-11	ELECT 10uF 20%	50V
C407	1-126-964-11	ELECT 10uF 20%	50V
C408	1-164-315-11	CERAMIC CHIP 470PF 5%	50V

Ref. No.	Part No.	Description	Remark	Ref. No.	Part No.	Description	Remark
C409	1-164-315-11	CERAMIC CHIP	470PF 5%			< FERRITE BEAD >	
C410	1-164-156-11	CERAMIC CHIP	0.1uF				
C411	1-164-156-11	CERAMIC CHIP	0.1uF				
C412	1-164-156-11	CERAMIC CHIP	0.1uF	L551	1-410-397-21	FERRITE 1.1uH	
C501	1-164-230-11	CERAMIC CHIP	220PF 5%	L552	1-410-397-21	FERRITE 1.1uH	
						< TRANSISTOR >	
C502	1-126-964-11	ELECT	10uF 20%				
C503	1-126-964-11	ELECT	10uF 20%	Q401	8-729-027-31	TRANSISTOR DTA124EKA-T146	
C505	1-136-165-00	FILM	0.1uF 5%	Q402	8-729-901-00	TRANSISTOR DTC124EK	
C506	1-136-165-00	FILM	0.1uF 5%	Q403	8-729-026-49	TRANSISTOR 2SA1037AK-T146-R	
C507	1-131-686-31	FILM	0.033uF 5%	Q404	8-729-119-79	TRANSISTOR 2SC2785-FEK	
				Q501	8-729-120-28	TRANSISTOR 2SC1623-L5L6	
C508	1-131-689-31	FILM	0.056uF 5%				
C509	1-136-165-00	FILM	0.1uF 5%	Q502	8-729-120-28	TRANSISTOR 2SC1623-L5L6	
C510	1-131-688-31	FILM	0.047uF 5%	Q503	8-729-026-49	TRANSISTOR 2SA1037AK-T146-R	
C511	1-131-698-31	FILM	0.33uF 5%	Q505	8-729-120-28	TRANSISTOR 2SC1623-L5L6	
C512	1-131-698-31	FILM	0.33uF 5%	Q506	8-729-027-44	TRANSISTOR DTC114TKA-T146	
				Q507	8-729-026-49	TRANSISTOR 2SA1037AK-T146-R	
C516	1-126-964-11	ELECT	10uF 20%				
C517	1-126-964-11	ELECT	10uF 20%	Q508	8-729-027-24	TRANSISTOR DTA114TKA-T146	
C518	1-126-964-11	ELECT	10uF 20%	Q551	8-729-119-79	TRANSISTOR 2SC2785-FEK	
C520	1-126-960-11	ELECT	1uF 20%	Q552	8-729-119-77	TRANSISTOR 2SA1175-FEK	
C521	1-126-960-11	ELECT	1uF 20%			< RESISTOR >	
C533	1-162-927-11	CERAMIC CHIP	100PF 5%				
C551	1-165-319-11	CERAMIC CHIP	0.1uF	R401	1-216-837-11	METAL CHIP 22K 5%	1/10W
C552	1-165-319-11	CERAMIC CHIP	0.1uF	R402	1-216-837-11	METAL CHIP 22K 5%	1/10W
C553	1-165-319-11	CERAMIC CHIP	0.1uF	R403	1-216-849-11	METAL CHIP 220K 5%	1/10W
C554	1-165-319-11	CERAMIC CHIP	0.1uF	R404	1-216-849-11	METAL CHIP 220K 5%	1/10W
				R405	1-216-846-11	METAL CHIP 120K 5%	1/10W
C555	1-104-665-11	ELECT	100uF 20%				
C556	1-104-665-11	ELECT	100uF 20%	R406	1-216-833-11	METAL CHIP 10K 5%	1/10W
C557	1-165-319-11	CERAMIC CHIP	0.1uF	R407	1-216-834-11	METAL CHIP 12K 5%	1/10W
C558	1-165-319-11	CERAMIC CHIP	0.1uF	R408	1-216-851-11	METAL CHIP 330K 5%	1/10W
C559	1-165-319-11	CERAMIC CHIP	0.1uF	R409	1-216-833-11	METAL CHIP 10K 5%	1/10W
				R410	1-216-845-11	METAL CHIP 100K 5%	1/10W
C560	1-136-165-00	FILM	0.1uF 5%				
				R411	1-216-841-11	METAL CHIP 47K 5%	1/10W
				R412	1-216-825-11	METAL CHIP 2.2K 5%	1/10W
				R413	1-216-841-11	METAL CHIP 47K 5%	1/10W
* CN401	1-564-709-11	PIN, CONNECTOR (SMALL TYPE) 7P		R503	1-216-841-11	METAL CHIP 47K 5%	1/10W
CN402	1-564-505-11	PLUG, CONNECTOR 2P		R504	1-216-841-11	METAL CHIP 47K 5%	1/10W
CN403	1-564-506-11	PLUG, CONNECTOR 3P					
				R505	1-216-841-11	METAL CHIP 47K 5%	1/10W
				R506	1-216-841-11	METAL CHIP 47K 5%	1/10W
				R508	1-216-833-11	METAL CHIP 10K 5%	1/10W
				R509	1-216-809-11	METAL CHIP 100 5%	1/10W
				R510	1-216-833-11	METAL CHIP 10K 5%	1/10W
D401	8-719-988-61	DIODE 1SS355TE-17					
D402	8-719-988-61	DIODE 1SS355TE-17		R511	1-216-847-11	METAL CHIP 150K 5%	1/10W
D403	8-719-988-61	DIODE 1SS355TE-17		R512	1-216-833-11	METAL CHIP 10K 5%	1/10W
D404	8-719-988-61	DIODE 1SS355TE-17		R513	1-216-829-11	METAL CHIP 4.7K 5%	1/10W
D405	8-719-109-93	DIODE RD6.2ESB2		R514	1-216-833-11	METAL CHIP 10K 5%	1/10W
				R515	1-216-833-11	METAL CHIP 10K 5%	1/10W
D500	8-719-988-61	DIODE 1SS355TE-17					
D501	8-719-988-61	DIODE 1SS355TE-17		R516	1-216-833-11	METAL CHIP 10K 5%	1/10W
D551	8-719-110-41	DIODE RD15ESB2		R517	1-216-838-11	METAL CHIP 27K 5%	1/10W
D552	8-719-110-41	DIODE RD15ESB2		R518	1-216-839-11	METAL CHIP 33K 5%	1/10W
				R519	1-216-833-11	METAL CHIP 10K 5%	1/10W
				R520	1-216-833-11	METAL CHIP 10K 5%	1/10W
FB501	1-410-397-21	FERRITE 1.1uH					
				R521	1-216-841-11	METAL CHIP 47K 5%	1/10W
				R522	1-216-845-11	METAL CHIP 100K 5%	1/10W
IC401	8-759-909-71	IC BA4558F		R523	1-216-841-11	METAL CHIP 47K 5%	1/10W
IC402	8-759-700-07	IC NJM2903M		R524	1-216-833-11	METAL CHIP 10K 5%	1/10W
IC501	8-759-909-71	IC BA4558F		R525	1-216-829-11	METAL CHIP 4.7K 5%	1/10W
IC502	8-759-909-71	IC BA4558F					
IC503	8-759-909-71	IC BA4558F		R526	1-216-829-11	METAL CHIP 4.7K 5%	1/10W
				R527	1-216-833-11	METAL CHIP 10K 5%	1/10W

# SA-FT7ED/WFT7/SS-CNF7ED/FRF7ED/WS-FT7

**FILTER** **INPUT** **LED** **POWER**

Ref. No.	Part No.	Description	Remark
R528	1-216-834-11	METAL CHIP 12K 5%	1/10W
R530	1-216-833-11	METAL CHIP 10K 5%	1/10W
R531	1-216-833-11	METAL CHIP 10K 5%	1/10W
R533	1-216-833-11	METAL CHIP 10K 5%	1/10W
R535	1-216-821-11	METAL CHIP 1K 5%	1/10W
R536	1-216-821-11	METAL CHIP 1K 5%	1/10W
R551	1-247-843-11	CARBON 3.3K 5%	1/4W
R552	1-247-843-11	CARBON 3.3K 5%	1/4W
< SWITCH >			
S401	1-570-707-31	SWITCH, SLIDE (POWER SAVE)	
S501	1-570-707-31	SWITCH, SLIDE (PHASE)	
< VARIABLE RESISTOR >			
VR501	1-227-696-11	RES, VAR 20K (BASS BOOST)	
VR502	1-227-696-11	RES, VAR 20K (LEVEL)	
*****			
A-1119-249-A	INPUT BOARD, COMPLETE *****		
< CAPACITOR >			
C701	1-162-927-11	CERAMIC CHIP 100PF 5%	50V
C702	1-216-864-11	SHORT CHIP 0	
< CONNECTOR >			
CN701	1-564-506-11	PLUG, CONNECTOR 3P	
< JACK >			
J701	1-779-797-11	JACK, PIN 1P (INPUT)	
< RESISTOR >			
R701	1-216-853-11	METAL CHIP 470K 5%	1/10W
*****			
LED BOARD *****			
< CAPACITOR >			
C801	1-164-156-11	CERAMIC CHIP 0.1uF	25V
C802	1-164-156-11	CERAMIC CHIP 0.1uF	25V
< CONNECTOR >			
* CN801	1-564-719-11	PIN, CONNECTOR (SMALL TYPE) 3P	
< DIODE >			
LD801	8-719-025-62	LED SML1216WTP4 (ON/STANDBY)	
*****			
POWER BOARD *****			
	4-931-757-31	SCREW (DIA.2.6X8) (IT3B), TAPPING	
	7-685-646-79	SCREW +BVTP 3X8 TYPE2 IT-3	
< CAPACITOR >			
△ C101	1-165-529-11	MYLAR 0.22uF 10%	275V
△ C103	1-165-528-11	MYLAR 0.1uF 10%	275V

Ref. No.	Part No.	Description	Remark
△ C104	1-113-920-11	CERAMIC 0.0022uF 20%	250V
△ C105	1-113-920-11	CERAMIC 0.0022uF 20%	250V
△ C110	1-113-920-11	CERAMIC 0.0022uF 20%	250V
△ C111	1-100-956-11	ELECT(BLOCK) 820uF 20%	250V (US,CND)
△ C112	1-100-956-11	ELECT(BLOCK) 820uF 20%	250V (US,CND)
△ C112	1-112-529-11	ELECT(BLOCK) 390uF 20%	450V (AEP,UK)
C113	1-165-319-11	CERAMIC CHIP 0.1uF	50V
C114	1-163-275-11	CERAMIC CHIP 0.001uF 5%	50V
C115	1-126-964-11	ELECT 10uF 20%	50V
C116	1-126-963-11	ELECT 4.7uF 20%	50V
C117	1-165-319-11	CERAMIC CHIP 0.1uF	50V
C118	1-163-009-11	CERAMIC CHIP 0.001uF 10%	50V
C119	1-164-222-11	CERAMIC CHIP 0.22uF	25V
C120	1-163-021-11	CERAMIC CHIP 0.01uF 10%	50V
C121	1-126-947-11	ELECT 47uF 20%	35V
△ C122	1-107-824-11	CERAMIC 220PF 5%	1KV
△ C123	1-107-824-11	CERAMIC 220PF 5%	1KV
△ C124	1-137-741-22	FILM 0.039uF 3%	800V
C127	1-126-950-11	ELECT 330uF 20%	35V
△ C131	1-113-898-11	CERAMIC 330PF 10%	250V
C151	1-100-924-21	ELECT 2200uF 20%	35V
C152	1-100-924-21	ELECT 2200uF 20%	35V
C155	1-165-319-11	CERAMIC CHIP 0.1uF	50V
C156	1-165-319-11	CERAMIC CHIP 0.1uF	50V
△ C202	1-113-924-11	CERAMIC 0.0047uF 20%	250V
△ C203	1-113-924-11	CERAMIC 0.0047uF 20%	250V
C204	1-126-942-61	ELECT 1000uF 20%	25V
C205	1-164-156-11	CERAMIC CHIP 0.1uF	25V
C206	1-164-156-11	CERAMIC CHIP 0.1uF	25V
C207	1-164-156-11	CERAMIC CHIP 0.1uF	25V
C208	1-164-156-11	CERAMIC CHIP 0.1uF	25V
C209	1-126-960-11	ELECT 1uF 20%	50V
C210	1-165-319-11	CERAMIC CHIP 0.1uF	50V
< CONNECTOR >			
CN201	1-564-321-00	PIN, CONNECTOR (3.96mm PITCH) 2P	
* CN202	1-564-705-11	PIN, CONNECTOR (SMALL TYPE) 3P	
* CN203	1-564-709-11	PIN, CONNECTOR (SMALL TYPE) 7P	
* CN205	1-564-511-11	PLUG, CONNECTOR 8P	
< DIODE >			
△ D101	8-719-082-57	DIODE D5SBA60F01	
D102	8-719-083-83	DIODE UDZS-TE17-15B	
D103	8-719-083-83	DIODE UDZS-TE17-15B	
D104	8-719-979-64	DIODE UF4005/23	
D105	8-719-083-83	DIODE UDZS-TE17-15B	
D106	8-719-083-83	DIODE UDZS-TE17-15B	
D107	8-719-063-70	DIODE D1NL20U	
D110	6-500-137-01	DIODE BAT54HT1	
D111	8-719-982-15	DIODE MTZJ-27B	
D151	6-501-225-01	DIODE D15XBN20	
D159	8-719-110-60	DIODE RD24ESB	
D201	8-719-991-33	DIODE 1SS133T-77	
D202	8-719-991-33	DIODE 1SS133T-77	
D203	8-719-991-33	DIODE 1SS133T-77	
D204	8-719-991-33	DIODE 1SS133T-77	

Ref. No.	Part No.	Description	Remark	Ref. No.	Part No.	Description	Remark
D205	8-719-991-33	DIODE 1SS133T-77		R206	1-216-841-11	METAL CHIP 47K 5%	1/10W
D206	8-719-991-33	DIODE 1SS133T-77		R207	1-216-841-11	METAL CHIP 47K 5%	1/10W
		< GROUND TERMINAL >		R208	1-216-841-11	METAL CHIP 47K 5%	1/10W
EP151	1-537-770-21	TERMINAL BOARD, GROUND		R209	1-216-841-11	METAL CHIP 47K 5%	1/10W
		< IC >		R210	1-216-827-11	METAL CHIP 3.3K 5%	1/10W
IC101	6-707-749-01	IC CXD9841P		R211	1-216-823-11	METAL CHIP 1.5K 5%	1/10W
		< LINE FILTER >		R212	1-216-841-11	METAL CHIP 47K 5%	1/10W
△ LF101	1-457-054-11	COIL, LINE FILTER (US,CND)		R213	1-216-845-11	METAL CHIP 100K 5%	1/10W
△ LF101	1-457-079-11	COIL, LINE FILTER (AEP,UK)				< RELAY >	
△ LF102	1-457-054-11	COIL, LINE FILTER (US,CND)		△ RY201	1-755-276-11	RELAY, POWER	
△ LF102	1-457-079-11	COIL, LINE FILTER (AEP,UK)		△ RY202	1-755-276-11	RELAY, POWER	
		< PHOTO INTERRUPTER >				< TRANSFORMER >	
PH101	6-600-187-01	PHOTO COUPLER PC123Y22FZ0F		△ T101	1-443-720-11	TRANSFORMER, DC-DC CONVERTER	
		< TRANSISTOR >		△ T201	1-443-717-11	TRANSFORMER, POWER (US,CND)	
Q101	6-551-339-01	FET 2SK3934(LBS2SONY,Q)		△ T201	1-443-718-11	TRANSFORMER, POWER (AEP,UK)	
Q102	6-551-339-01	FET 2SK3934(LBS2SONY,Q)				< THERMISTOR >	
Q201	8-729-027-31	TRANSISTOR DTA124EKA-T146		△ TH101	1-805-841-21	THERMISTOR, NTC 3.0 (US,CND)	
Q202	8-729-027-31	TRANSISTOR DTA124EKA-T146		△ TH101	1-805-842-21	THERMISTOR, NTC 6.0 (AEP,UK)	
Q203	8-729-120-28	TRANSISTOR 2SC1623-L5L6				*****	
Q204	8-729-026-49	TRANSISTOR 2SA1037AK-T146-R				SW BOARD	
Q205	8-729-120-28	TRANSISTOR 2SC1623-L5L6				*****	
Q206	8-729-027-31	TRANSISTOR DTA124EKA-T146				< CAPACITOR >	
Q207	8-729-901-00	TRANSISTOR DTC124EK		△ C301	1-113-915-11	CERAMIC 0.001uF 20% 250V	
Q208	8-729-901-00	TRANSISTOR DTC124EK				< CONNECTOR >	
		< RESISTOR >		* CN301	1-580-230-11	PIN, CONNECTOR (PC BOARD) 2P	
△ R101	1-219-759-11	METAL 1M 5%	1/2W F	CN302	1-564-321-00	PIN, CONNECTOR (3.96mm PITCH) 2P	
R111	1-245-478-21	METAL 470K 1%	1/4W			< SWITCH >	
R112	1-245-478-21	METAL 470K 1%	1/4W	△ S301	1-786-847-11	SWITCH, POWER (POWER)	
R113	1-216-673-11	METAL CHIP 8.2K 0.5%	1/10W			*****	
R114	1-216-679-11	METAL CHIP 15K 0.5%	1/10W			MISCELLANEOUS	
R115	1-216-627-11	METAL CHIP 100 0.5%	1/10W			*****	
R116	1-216-627-11	METAL CHIP 100 0.5%	1/10W	3	1-826-119-11	LOUDSPEAKER (10cm) (SS-FRF7ED)	
R117	1-249-923-11	CARBON 1K 1%	1/4W	7	1-826-120-21	LOUDSPEAKER (2cm) (SS-FRF7ED)	
R118	1-249-393-11	CARBON 10 5%	1/4W	53	1-826-121-11	LOUDSPEAKER (8cm) (SS-CNF7ED)	
R119	1-216-073-00	RES-CHIP 10K 5%	1/10W	55	1-826-120-21	LOUDSPEAKER (2cm) (SS-CNF7ED)	
R120	1-249-393-11	CARBON 10 5%	1/4W	60	1-780-292-21	TERMINAL (BLACK) (SS-CNF7ED)	
R121	1-216-073-00	RES-CHIP 10K 5%	1/10W	61	1-780-292-11	TERMINAL (RED) (SS-CNF7ED)	
△ R122	1-219-984-51	METAL 0.1 5%	2W F	112	1-780-292-11	TERMINAL (RED) (WS-FT7)	
R123	1-247-692-11	CARBON 22 5%	1/4W	113	1-780-292-21	TERMINAL (BLACK) (WS-FT7)	
R124	1-216-821-11	METAL CHIP 1K 5%	1/10W	△ 206	1-751-528-11	CORD, POWER (UK) (SA-WFT7)	
R130	1-216-627-11	METAL CHIP 100 0.5%	1/10W	△ 206	1-769-744-52	CORD, POWER (AEP) (SA-WFT7)	
R131	1-216-835-11	METAL CHIP 15K 5%	1/10W	△ 206	1-783-531-12	CORD, POWER (US,CND) (SA-WFT7)	
R132	1-249-899-11	CARBON 100 1%	1/4W	△ F901	1-576-230-51	FUSE (T3.15AH/250V) (SA-WFT7:AEP,UK)	
R133	1-216-603-11	METAL CHIP 10 0.5%	1/10W	△ F901	1-576-233-51	FUSE (6.3A/250V) (SA-WFT7:US,CND)	
R134	1-216-651-11	METAL CHIP 1K 0.5%	1/10W	SP901	1-826-122-11	LOUDSPEAKER (15cm) (SA-WFT7)	
R151	1-216-817-11	METAL CHIP 470 5%	1/10W			*****	
R152	1-216-821-11	METAL CHIP 1K 5%	1/10W				
R201	1-216-841-11	METAL CHIP 47K 5%	1/10W				
R202	1-216-845-11	METAL CHIP 100K 5%	1/10W				
R203	1-216-841-11	METAL CHIP 47K 5%	1/10W				
R205	1-216-841-11	METAL CHIP 47K 5%	1/10W				

# SA-FT7ED/WFT7/SS-CNF7ED/FRF7ED/WS-FT7

Ver. 1.1

Ref. No.	Part No.	Description	Remark
		ACCESSORIES *****	
	1-751-598-43	CORD, CONNECTION (PIN-PIN) (2m)	
	1-819-535-11	ADAPTOR (for SA-WFT7)	
	2-597-467-01	CLOTH, CLEANING	
	2-630-937-01	SEAL, BLIND	
	2-634-474-11	MANUAL, INSTRUCTION (ENGLISH,FRENCH) (SA-FT7ED:US,CND)	
	2-634-474-21	MANUAL, INSTRUCTION (ENGLISH,FRENCH) (SA-FT7ED:AEP,UK)	
	2-634-474-31	MANUAL, INSTRUCTION (GERMAN,SPANISH) (SA-FT7ED:AEP)	
	2-634-474-41	MANUAL, INSTRUCTION (DUTCH,SWEDISH) (SA-FT7ED:AEP)	
	2-634-474-51	MANUAL, INSTRUCTION (ITALIAN,POLISH) (SA-FT7ED:AEP)	
	2-634-474-61	MANUAL, INSTRUCTION (FINNISH,DANISH) (SA-FT7ED:AEP)	
	2-634-474-71	MANUAL, INSTRUCTION (PORTUGUESE, RUSSIAN) (SA-FT7ED:AEP)	
	2-636-262-11	MANUAL, INSTRUCTION (ENGLISH,FRENCH, GERMAN,SPANISH,DUTCH,SWEDISH,ITALIAN, PORTUGUESE,DANISH,FINNISH,POLISH, RUSSIAN,TRADITIONAL CHINESE) (WS-FT7)	
	2-636-262-21	MANUAL, INSTRUCTION (CZECH,GREEK, HUNGARIAN,SLOVAKIAN,TURKISH) (WS-FT7:AEP)	
	2-636-291-11	MANUAL, INSTRUCTION (ENGLISH,FRENCH, GERMAN,SPANISH) (SS-FRF7ED)	
	2-636-291-21	MANUAL, INSTRUCTION (DUTCH,SWEDISH, ITALIAN,POLISH) (SS-FRF7ED:AEP,UK)	
	2-636-291-31	MANUAL, INSTRUCTION (PORTUGUESE, DANISH,FINNISH,RUSSIAN) (SS-FRF7ED:AEP,UK)	
	2-636-291-41	MANUAL, INSTRUCTION (SLOVAKIAN, TURKISH) (SS-FRF7ED:AEP,UK)	
	2-636-291-51	MANUAL, INSTRUCTION (CZECH,GREEK, HUNGARIAN) (SS-FRF7ED:AEP,UK)	

Ref. No.	Part No.	Description	Remark
		PARTS FOR INSTALLATION AND CONNECTIONS *****	
	301	1-791-467-31 CORD, SPEAKER (3.5m)	
	302	1-791-467-11 CORD, SPEAKER (10m)	
	303	7-683-422-04 BOLT, HEXAGON SOCKET 4X14 (for TERMINAL BOARD (DT) ASSY and SS-FRF7ED)	
	304	7-623-210-22 SW 4, TYPE 2	
*	305	4-985-459-01 WRENCH, HEXAGON SHAFT	
	306	A-1121-187-A TERMINAL BOARD (DT) ASSY (including ▲)	
	307	7-682-576-04 SCREW +B 5X12	
	308	7-623-926-11 WASHER 5.0, NYLON	
	309	7-682-561-04 SCREW +B 4X8 (for HOOK (CUSHION TO))	
	310	2-630-936-01 HOOK (CUSHION TO)	
	311	X-2059-329-1 BRACKET (CN) ASSY	
	▲	1-780-292-11 TERMINAL (RED)	
	▲	1-780-292-21 TERMINAL (BLACK)	

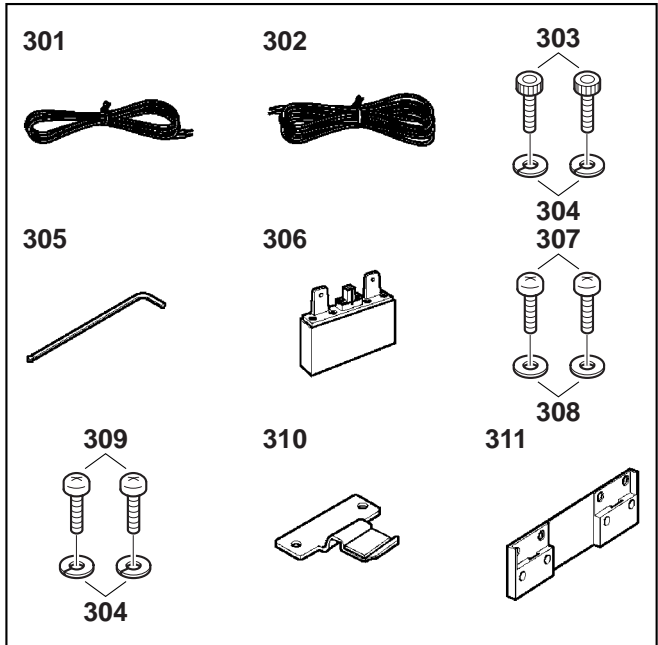

\*\*\*\*\*



# SA-FT7ED/WFT7/SS-CNF7ED/ FRF7ED/WS-FT7

**SONY**<sup>®</sup>

## SERVICE MANUAL

Ver. 1.1 2005. 11

*US Model  
Canadian Model  
AEP Model  
UK Model*

### SUPPLEMENT-1

File this supplement with the service manual.

**Subject :** Change of circuit boards.

When performing service and inspection, check the suffix of the part number of the circuit board.

**DISCRIMINATION**

**- POWER BOARD (component side) -**

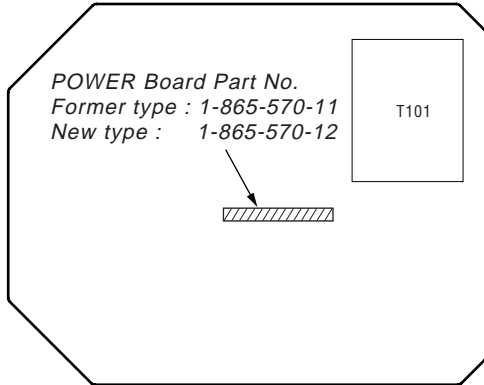

**- AMP BOARD (component side) -**

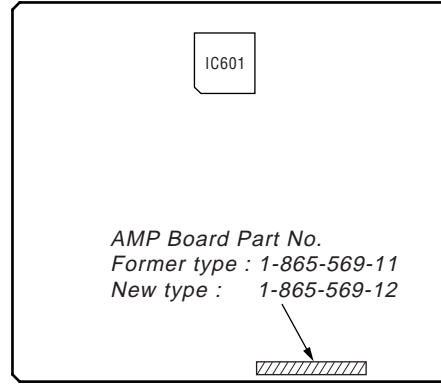

**- INPUT BOARD (component side) -**

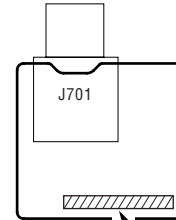

INPUT Board Part No.  
Former type : 1-865-572-11  
New type : 1-865-572-12

**- FILTER BOARD (component side) -**

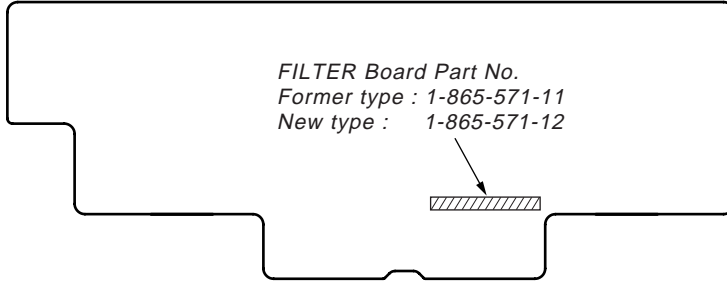

**- ACIN BOARD (component side) -**

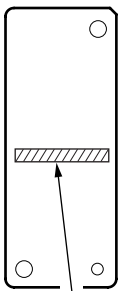

ACIN Board Part No.  
Former type : 1-865-574-11  
New type : 1-865-574-12

**- SW BOARD (component side) -**

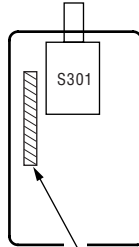

SW Board Part No.  
Former type : 1-865-573-11  
New type : 1-865-573-12

**- LED BOARD (component side) -**

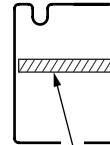

LED Board Part No.  
Former type : 1-865-575-11  
New type : 1-865-575-12

**TABLE OF CONTENTS**



**1. DIAGRAMS**

1-1. Printed Wiring Boards –Filter Section– ..... 5  
1-2. Schematic Diagram –Filter Section– ..... 6  
1-3. Printed Wiring Board –Amp Section (1/2)– ..... 7  
1-4. Printed Wiring Board –Amp Section (2/2)– ..... 8  
1-5. Schematic Diagram –Amp Section– ..... 9  
1-6. Printed Wiring Boards –Power Section– ..... 10  
1-7. Schematic Diagram –Power Section– ..... 11



**2. ELECTRICAL PARTS LIST ..... 12**

SECTION 1  
DIAGRAMS



**Note on Schematic Diagram:**

- All capacitors are in  $\mu\text{F}$  unless otherwise noted. (p: pF) 50 WV or less are not indicated except for electrolytics and tantalums.
- All resistors are in  $\Omega$  and  $1/4\text{W}$  or less unless otherwise specified.
-  : nonflammable resistor.
-  : panel designation.

<p><b>Note:</b> The components identified by mark <math>\triangle</math> or dotted line with mark <math>\triangle</math> are critical for safety. Replace only with part number specified.</p>	<p><b>Note:</b> Les composants identifiés par une marque <math>\triangle</math> sont critiques pour la sécurité. Ne les remplacer que par une pièce portant le numéro spécifié.</p>
--	---

-  : B+ Line.
-  : B- Line.
- Voltage is dc with respect to ground under no-signal (detuned) condition.
- Voltages are taken with a VOM (Input impedance  $10\text{M}\Omega$ ). Voltage variations may be noted due to normal production tolerances.
- no mark : POWER ON
- \* : Impossible to measure
- Signal path.
-  : LINE
- Abbreviation
- CND : Canadian model.

**Note on Printed Wiring Boards:**

-  : parts extracted from the component side.
-  : Pattern from the side which enables seeing.
- Abbreviation
- CND : Canadian model.

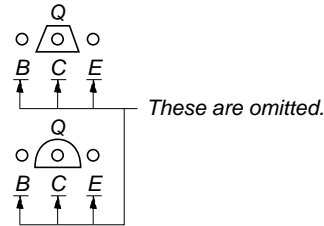
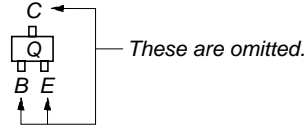

1-1. PRINTED WIRING BOARDS — FILTER SECTION —

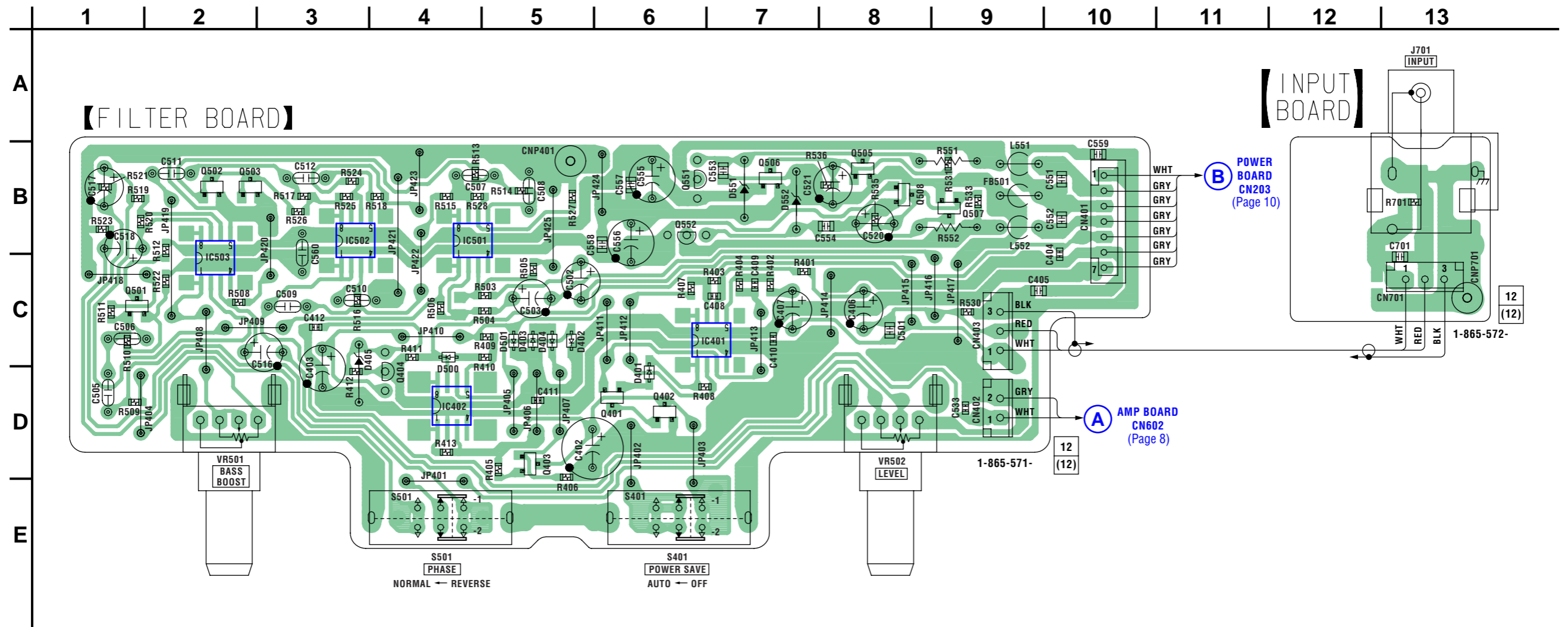

• Semiconductor Location

Ref. No.	Location
D401	D-6
D402	C-5
D403	C-5
D404	C-5
D405	C-3
D500	C-4
D501	C-5
D551	B-7
D552	B-7
IC401	C-7
IC402	D-4
IC501	B-4
IC502	B-3
IC503	C-2
Q401	D-6
Q402	D-6
Q403	D-5
Q404	D-4
Q501	C-1
Q502	B-2
Q503	B-2
Q505	B-8
Q506	B-7
Q507	B-9
Q508	B-8
Q551	B-6
Q552	B-6

1-2. SCHEMATIC DIAGRAM — FILTER SECTION —

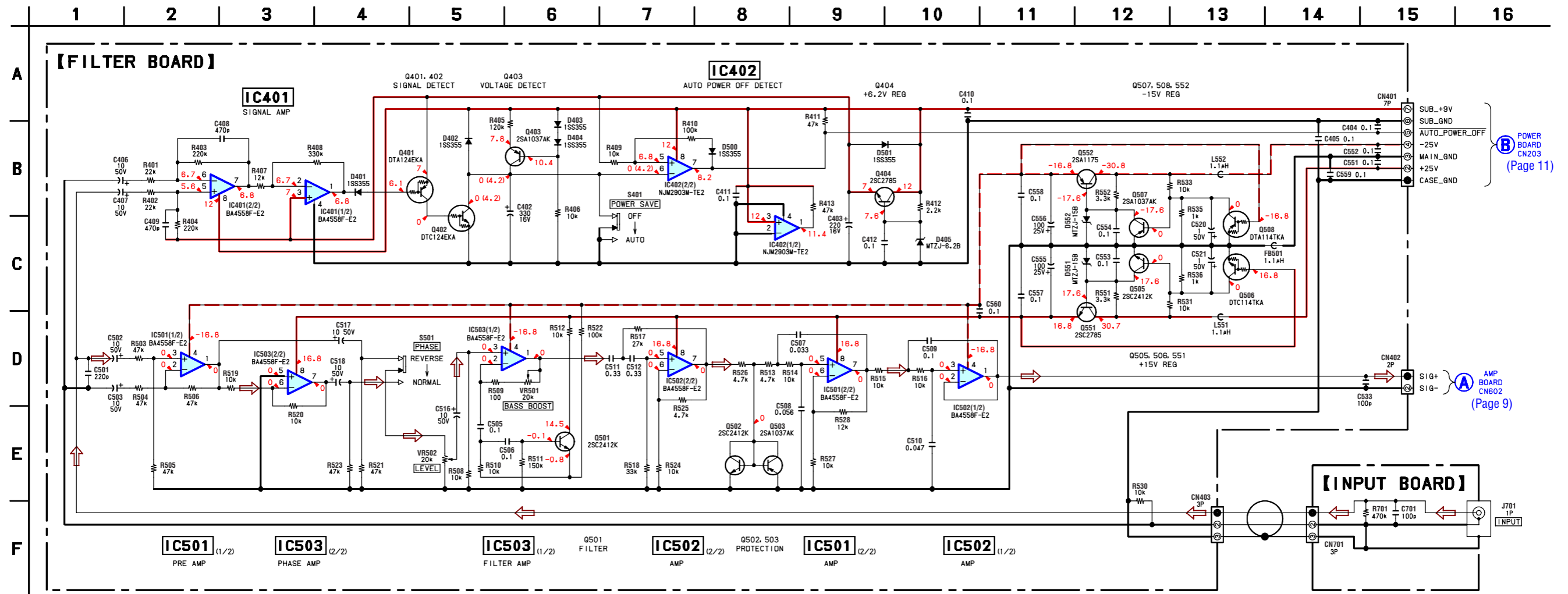

1-3. PRINTED WIRING BOARD — AMP SECTION (1/2) —

14 | 13 | 12 | 11 | 10 | 9 | 8 | 7 | 6 | 5 | 4 | 3 | 2 | 1

【AMP BOARD】(SIDE A)

• Semiconductor Location (Side A)

Ref. No.	Location
IC601	C-6
Q603	B-8
Q691	B-5

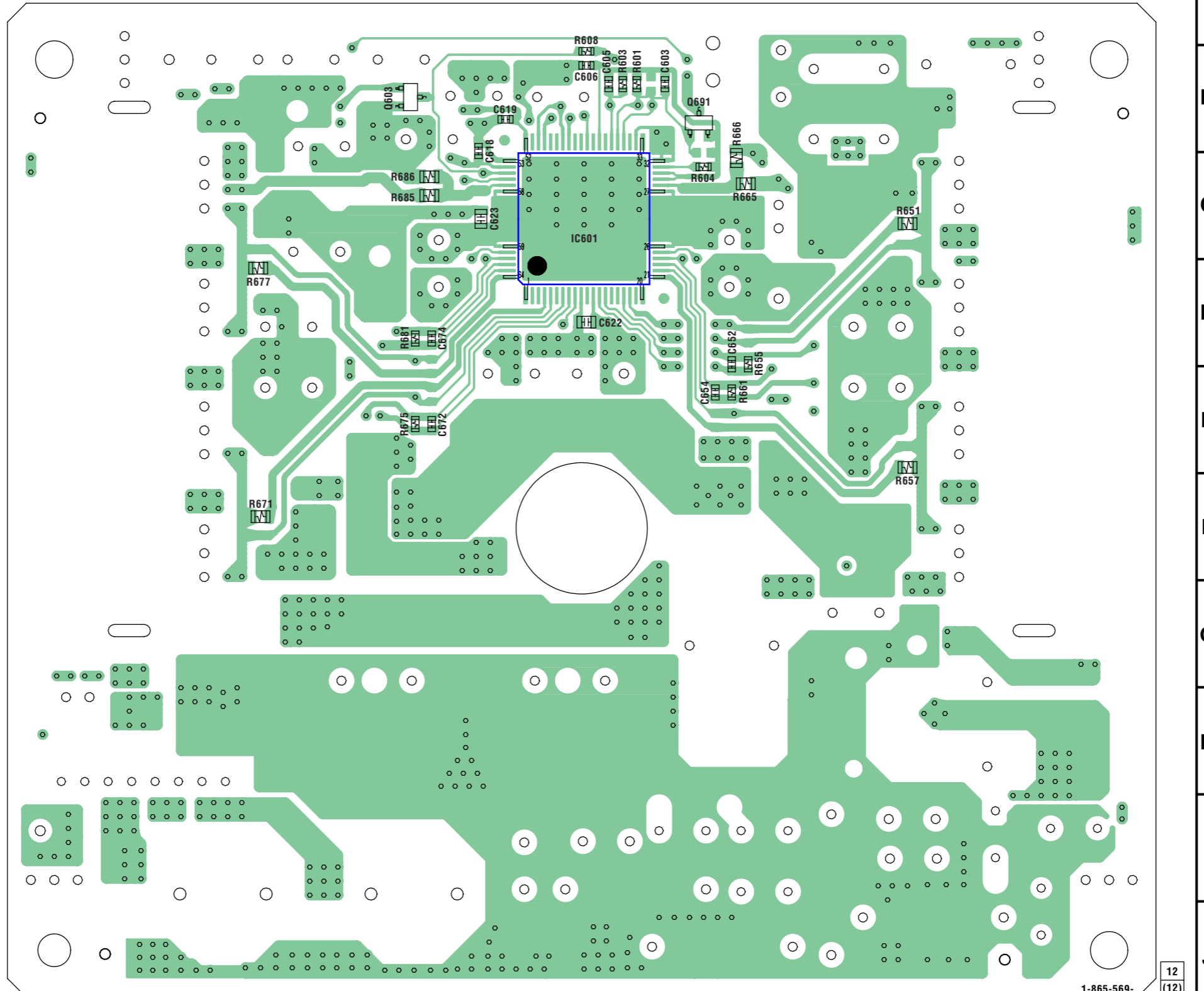

1-865-569-

12  
(12)

1-4. PRINTED WIRING BOARD — AMP SECTION (2/2) —

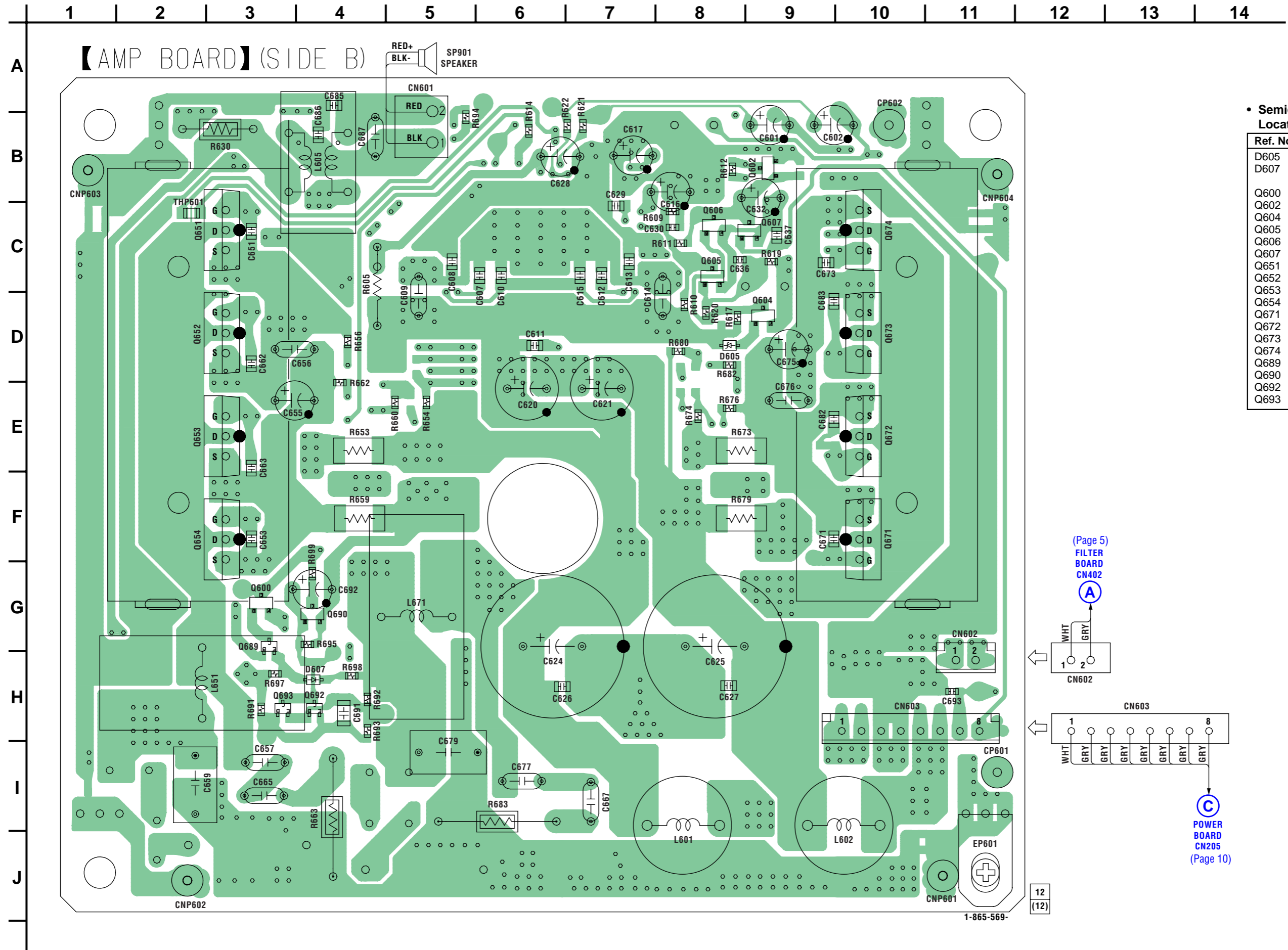

• Semiconductor Location (Side B)

Ref. No.	Location
D605	D-8
D607	H-4
Q600	G-3
Q602	B-9
Q604	D-9
Q605	C-8
Q606	C-8
Q607	C-9
Q651	C-3
Q652	D-3
Q653	E-3
Q654	F-3
Q671	F-10
Q672	E-10
Q673	D-10
Q674	C-10
Q689	G-3
Q690	G-4
Q692	H-4
Q693	H-3

(Page 5)  
FILTER  
BOARD  
CN402

A

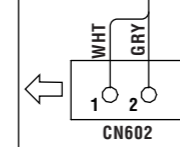

CN603

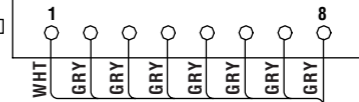

C  
POWER  
BOARD  
CN205  
(Page 10)

12  
(12)

1-865-569-



1-5. SCHEMATIC DIAGRAM — AMP SECTION —

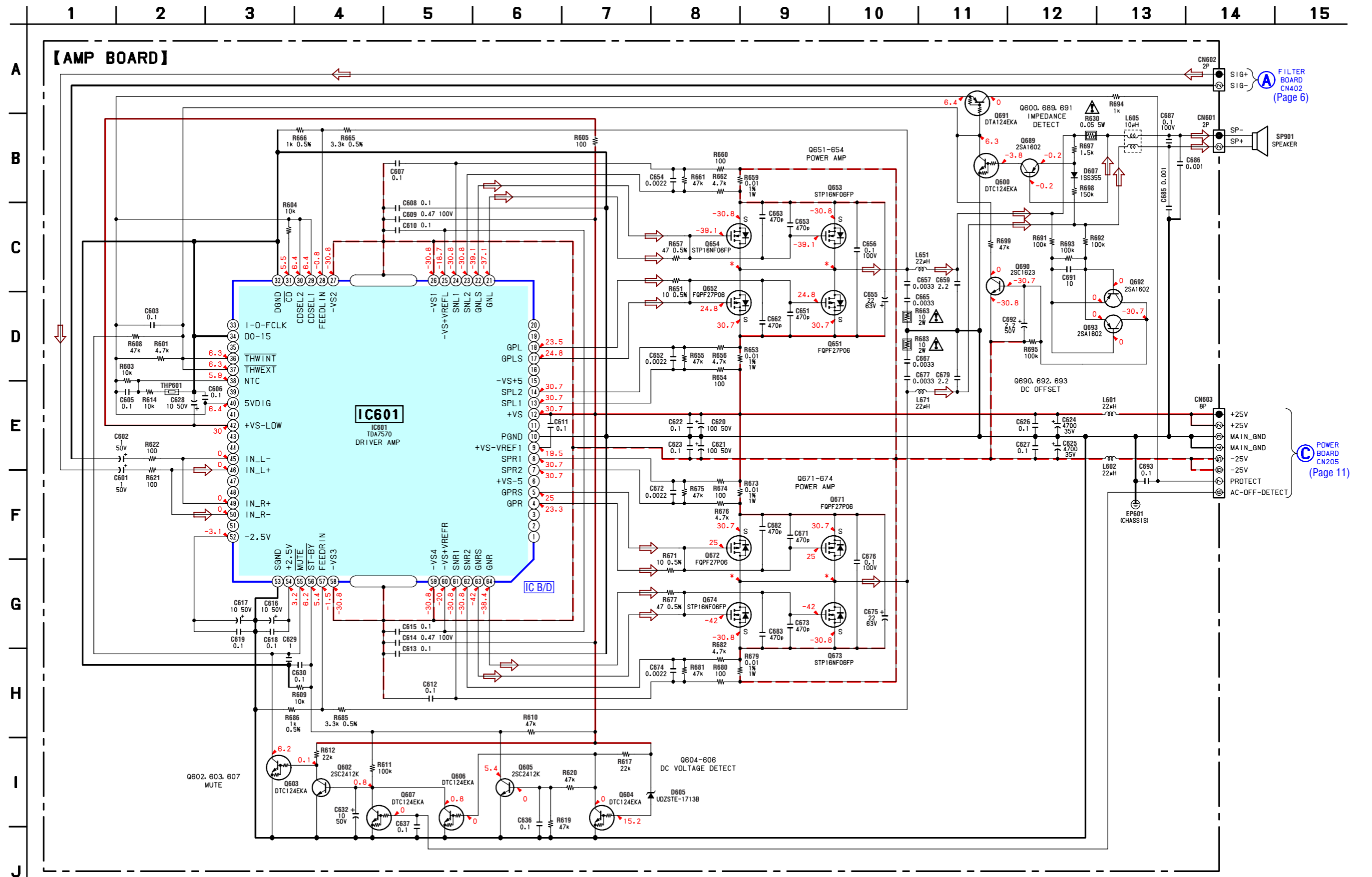

FILTER BOARD CN402 (Page 6)

POWER BOARD CN205 (Page 11)

1-6. PRINTED WIRING BOARDS — POWER SECTION —

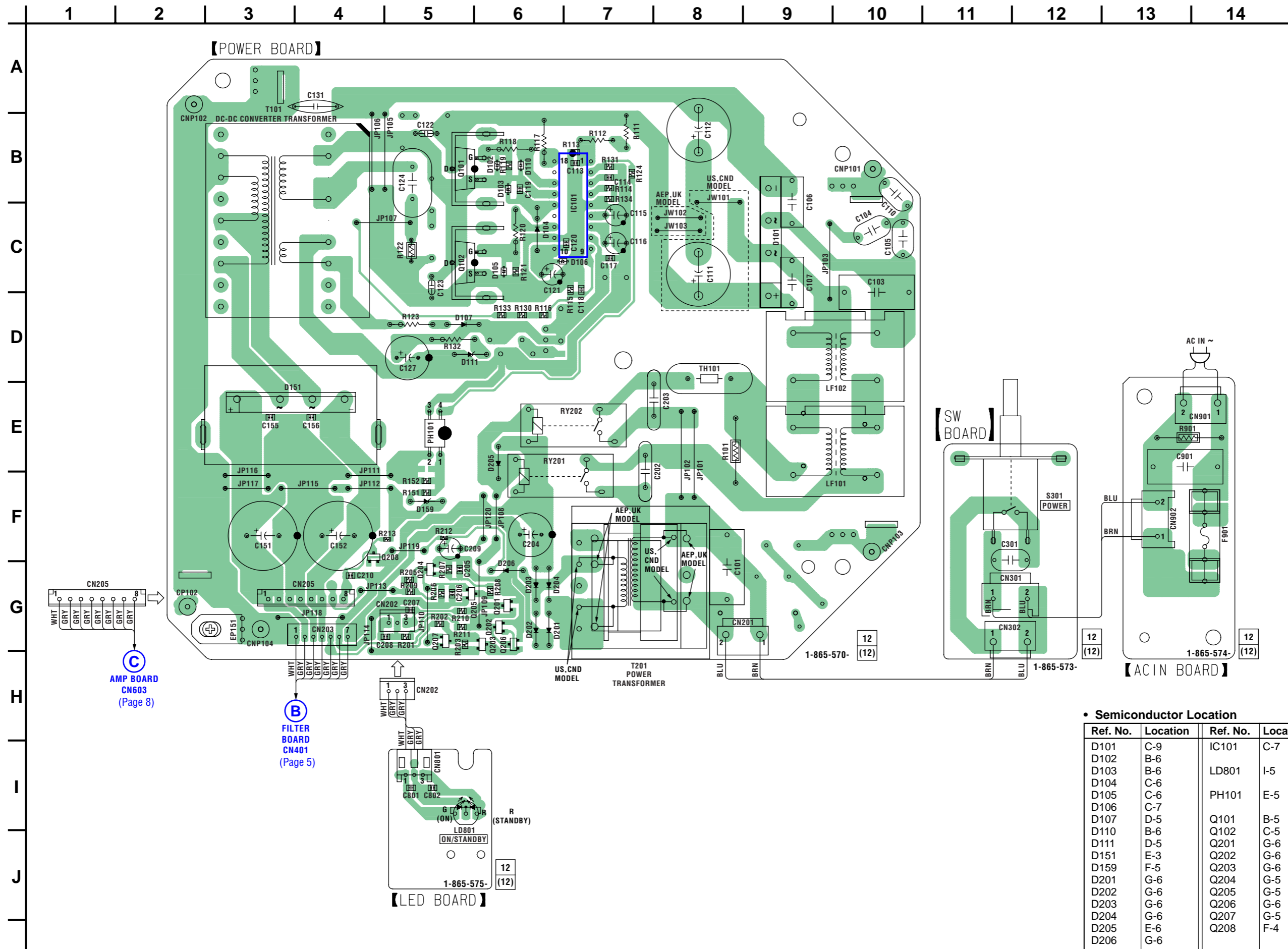

• Semiconductor Location

Ref. No.	Location	Ref. No.	Location
D101	C-9	IC101	C-7
D102	B-6	LD801	I-5
D103	B-6		
D104	C-6		
D105	C-6	PH101	E-5
D106	C-7		
D107	D-5	Q101	B-5
D110	B-6	Q102	C-5
D111	D-5	Q201	G-6
D151	E-3	Q202	G-6
D159	F-5	Q203	G-6
D201	G-6	Q204	G-5
D202	G-6	Q205	G-5
D203	G-6	Q206	G-6
D204	G-6	Q207	G-5
D205	E-6	Q208	F-4
D206	G-6		

1-7. SCHEMATIC DIAGRAM — POWER SECTION —

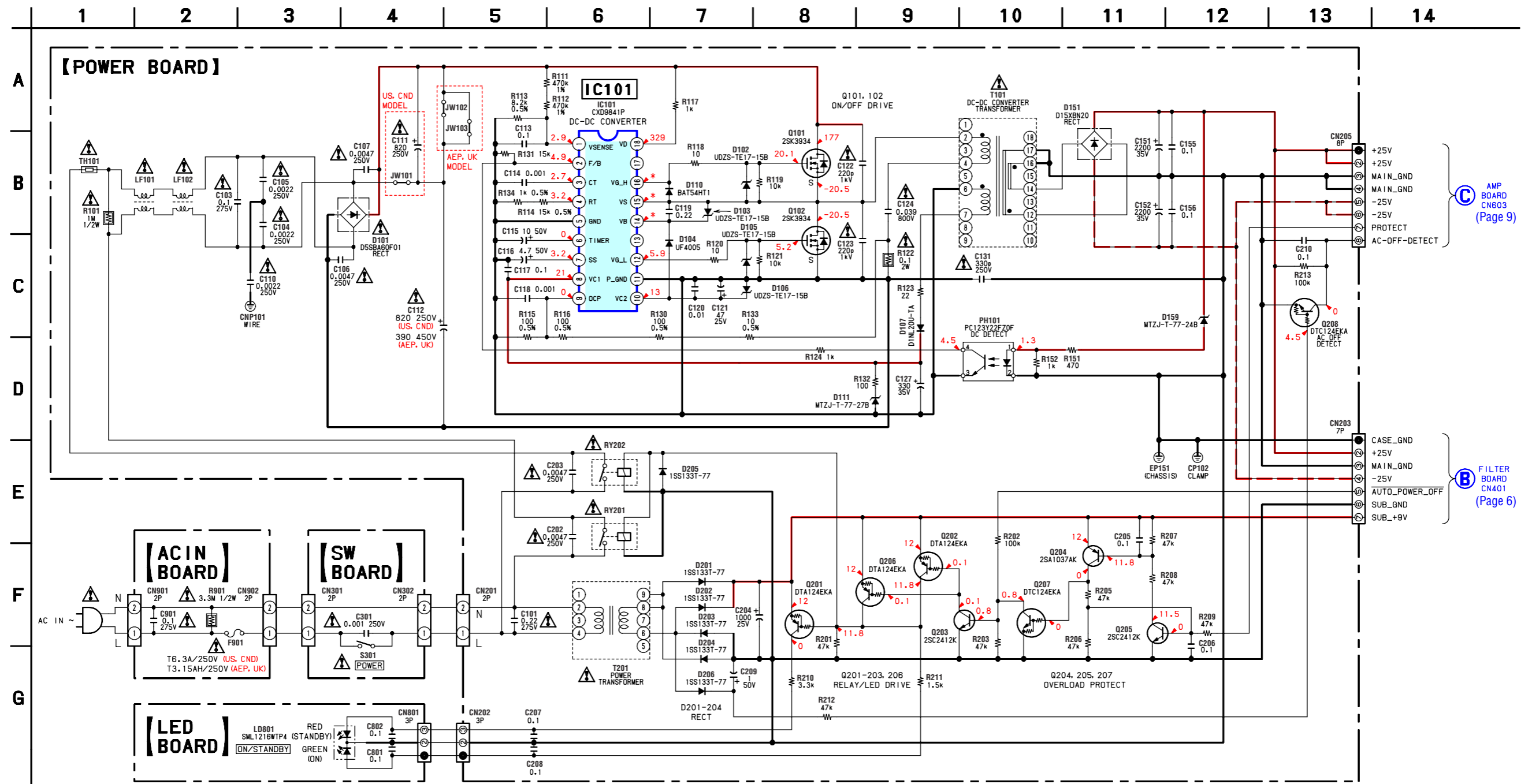

SECTION 2

ELECTRICAL PARTS LIST

ACIN AMP

AMP FILTER

NOTE:

- Due to standardization, replacements in the parts list may be different from the parts specified in the diagrams or the components used on the set.
- -XX and -X mean standardized parts, so they may have some difference from the original one.
- RESISTORS  
All resistors are in ohms.  
METAL: Metal-film resistor.  
METAL OXIDE: Metal oxide-film resistor.  
F: nonflammable
- Abbreviation  
CND : Canadian model

- Items marked "\*" are not stocked since they are seldom required for routine service. Some delay should be anticipated when ordering these items.
- SEMICONDUCTORS  
In each case, u : μ, for example:  
uA.. : μA.. uPA.. : μPA..  
uPB.. : μPB.. uPC.. : μPC.. uPD.. : μPD..
- CAPACITORS  
uF : μF
- COILS  
uH : μH

The components identified by mark Δ or dotted line with mark Δ are critical for safety. Replace only with part number specified.

Les composants identifiés par une marque Δ sont critiques pour la sécurité. Ne les remplacer que par une pièce portant le numéro spécifié.

When indicating parts by reference number, please include the board.

Ref. No.	Part No.	Description	Remark
		ACIN BOARD *****	
	1-533-313-11	HOLDER, FUSE	
		< CAPACITOR >	
Δ C901	1-165-528-11	MYLAR 0.1uF 10%	275V
		< CONNECTOR >	
CN901	1-564-321-00	PIN, CONNECTOR (3.96mm PITCH) 2P	
* CN902	1-580-230-11	PIN, CONNECTOR (PC BOARD) 2P	
		< RESISTOR >	
Δ R901	1-219-237-11	SOLID 3.3M 20%	1/2W F
		*****	
	A-1119-253-A	AMP BOARD, COMPLETE *****	
	4-931-757-31	SCREW (DIA. 2.6X8) (IT3B), TAPPING	
		< CAPACITOR >	
C601	1-126-960-11	ELECT 1uF 20%	50V
C602	1-126-960-11	ELECT 1uF 20%	50V
C603	1-164-156-11	CERAMIC CHIP 0.1uF	25V
C605	1-164-156-11	CERAMIC CHIP 0.1uF	25V
C606	1-164-156-11	CERAMIC CHIP 0.1uF	25V
C607	1-165-319-11	CERAMIC CHIP 0.1uF	50V
C608	1-165-319-11	CERAMIC CHIP 0.1uF	50V
C609	1-137-959-11	MYLAR 0.47uF 5%	100V
C610	1-165-319-11	CERAMIC CHIP 0.1uF	50V
C611	1-165-319-11	CERAMIC CHIP 0.1uF	50V
C612	1-165-319-11	CERAMIC CHIP 0.1uF	50V
C613	1-165-319-11	CERAMIC CHIP 0.1uF	50V
C614	1-137-959-11	MYLAR 0.47uF 5%	100V
C615	1-165-319-11	CERAMIC CHIP 0.1uF	50V
C616	1-126-964-11	ELECT 10uF 20%	50V
C617	1-126-964-11	ELECT 10uF 20%	50V
C618	1-164-156-11	CERAMIC CHIP 0.1uF	25V
C619	1-164-156-11	CERAMIC CHIP 0.1uF	25V
C620	1-126-968-11	ELECT 100uF 20%	50V
C621	1-126-968-11	ELECT 100uF 20%	50V
C622	1-165-319-11	CERAMIC CHIP 0.1uF	50V
C623	1-165-319-11	CERAMIC CHIP 0.1uF	50V
C624	1-107-900-51	ELECT 4700uF 20%	35V

Ref. No.	Part No.	Description	Remark
C625	1-107-900-51	ELECT 4700uF 20%	35V
C626	1-165-319-11	CERAMIC CHIP 0.1uF	50V
C627	1-165-319-11	CERAMIC CHIP 0.1uF	50V
C628	1-126-964-11	ELECT 10uF 20%	50V
C629	1-164-346-11	CERAMIC CHIP 1uF	16V
C630	1-164-156-11	CERAMIC CHIP 0.1uF	25V
C632	1-126-964-11	ELECT 10uF 20%	50V
C636	1-164-156-11	CERAMIC CHIP 0.1uF	25V
C637	1-165-319-11	CERAMIC CHIP 0.1uF	50V
C651	1-163-005-11	CERAMIC CHIP 470PF 10%	50V
C652	1-162-966-11	CERAMIC CHIP 0.0022uF 10%	50V
C653	1-163-005-11	CERAMIC CHIP 470PF 10%	50V
C654	1-162-966-11	CERAMIC CHIP 0.0022uF 10%	50V
C655	1-128-551-11	ELECT 22uF 20%	63V
C656	1-130-777-00	MYLAR 0.1uF 5%	100V
C657	1-130-477-00	MYLAR 0.0033uF 5%	50V
C659	1-135-621-51	FILM 2.2uF 5%	50V
C662	1-163-005-11	CERAMIC CHIP 470PF 10%	50V
C663	1-163-005-11	CERAMIC CHIP 470PF 10%	50V
C665	1-130-477-00	MYLAR 0.0033uF 5%	50V
C667	1-130-477-00	MYLAR 0.0033uF 5%	50V
C671	1-163-005-11	CERAMIC CHIP 470PF 10%	50V
C672	1-162-966-11	CERAMIC CHIP 0.0022uF 10%	50V
C673	1-163-005-11	CERAMIC CHIP 470PF 10%	50V
C674	1-162-966-11	CERAMIC CHIP 0.0022uF 10%	50V
C675	1-128-551-11	ELECT 22uF 20%	63V
C676	1-130-777-00	MYLAR 0.1uF 5%	100V
C677	1-130-477-00	MYLAR 0.0033uF 5%	50V
C679	1-135-621-51	FILM 2.2uF 5%	50V
C682	1-163-005-11	CERAMIC CHIP 470PF 10%	50V
C683	1-163-005-11	CERAMIC CHIP 470PF 10%	50V
C685	1-163-009-11	CERAMIC CHIP 0.001uF 10%	50V
C686	1-163-009-11	CERAMIC CHIP 0.001uF 10%	50V
C687	1-130-777-00	MYLAR 0.1uF 5%	100V
C691	1-117-370-11	CERAMIC CHIP 10uF	10V
C692	1-126-961-11	ELECT 2.2uF 20%	50V
C693	1-164-156-11	CERAMIC CHIP 0.1uF	25V
		< CONNECTOR >	
CN601	1-564-320-00	PIN, CONNECTOR (3.96mm PITCH) 2P	
CN602	1-564-505-11	PLUG, CONNECTOR 2P	
* CN603	1-564-511-11	PLUG, CONNECTOR 8P	

Ref. No.	Part No.	Description	Remark
		< DIODE >	
D605	8-719-083-63	DIODE UDZSTE-1713B	
D607	8-719-988-61	DIODE 1SS355TE-17	
		< GROUND TERMINAL >	
EP601	1-537-770-21	TERMINAL BOARD, GROUND	
		< IC >	
IC601	6-708-086-01	IC TDA7570	
		< COIL >	
L601	1-400-242-11	INDUCTOR 22uH	
L602	1-400-242-11	INDUCTOR 22uH	
L605	1-457-137-11	COIL, CHOKE 10uH	
L651	1-457-100-11	INDUCTOR 22uH	
L671	1-457-100-11	INDUCTOR 22uH	
		< TRANSISTOR >	
Q600	8-729-901-00	TRANSISTOR DTC124EK	
Q602	8-729-120-28	TRANSISTOR 2SC1623-L5L6	
Q603	8-729-901-00	TRANSISTOR DTC124EK	
Q604	8-729-901-00	TRANSISTOR DTC124EK	
Q605	8-729-120-28	TRANSISTOR 2SC1623-L5L6	
Q606	8-729-901-00	TRANSISTOR DTC124EK	
Q607	8-729-901-00	TRANSISTOR DTC124EK	
Q651	6-551-313-01	FET FQPF27P06	
Q652	6-551-313-01	FET FQPF27P06	
Q653	6-551-309-01	FET STP16NF06FP	
Q654	6-551-309-01	FET STP16NF06FP	
Q671	6-551-313-01	FET FQPF27P06	
Q672	6-551-313-01	FET FQPF27P06	
Q673	6-551-309-01	FET STP16NF06FP	
Q674	6-551-309-01	FET STP16NF06FP	
Q689	8-729-602-36	TRANSISTOR 2SA1602-F	
Q690	8-729-120-28	TRANSISTOR 2SC1623-L5L6	
Q691	8-729-027-31	TRANSISTOR DTA124EKA-T146	
Q692	8-729-602-36	TRANSISTOR 2SA1602-F	
Q693	8-729-602-36	TRANSISTOR 2SA1602-F	
		< RESISTOR >	
R601	1-216-829-11	METAL CHIP 4.7K 5%	1/10W
R603	1-216-833-11	METAL CHIP 10K 5%	1/10W
R604	1-216-833-11	METAL CHIP 10K 5%	1/10W
R605	1-249-899-11	CARBON 100 1%	1/4W
R608	1-216-841-11	METAL CHIP 47K 5%	1/10W
R609	1-216-833-11	METAL CHIP 10K 5%	1/10W
R610	1-216-841-11	METAL CHIP 47K 5%	1/10W
R611	1-216-845-11	METAL CHIP 100K 5%	1/10W
R612	1-216-837-11	METAL CHIP 22K 5%	1/10W
R614	1-216-833-11	METAL CHIP 10K 5%	1/10W
R617	1-216-837-11	METAL CHIP 22K 5%	1/10W
R619	1-216-841-11	METAL CHIP 47K 5%	1/10W
R620	1-216-841-11	METAL CHIP 47K 5%	1/10W
R621	1-216-809-11	METAL CHIP 100 5%	1/10W
R622	1-216-809-11	METAL CHIP 100 5%	1/10W
Δ R630	1-243-665-11	METAL 0.05 5%	5W F
R651	1-216-603-11	METAL CHIP 10 0.5%	1/10W

Ref. No.	Part No.	Description	Remark
R653	1-219-684-11	RES-CHIP 0.01	1% 1W
R654	1-216-809-11	METAL CHIP 100	5% 1/10W
R655	1-216-841-11	METAL CHIP 47K	5% 1/10W
R656	1-216-829-11	METAL CHIP 4.7K	5% 1/10W
R657	1-216-619-11	METAL CHIP 47	0.5% 1/10W
R659	1-219-684-11	RES-CHIP 0.01	1% 1W
R660	1-216-809-11	METAL CHIP 100	5% 1/10W
R661	1-216-841-11	METAL CHIP 47K	5% 1/10W
R662	1-216-829-11	METAL CHIP 4.7K	5% 1/10W
Δ R663	1-215-880-00	METAL OXIDE 10	5% 2W F
R665	1-216-663-11	METAL CHIP 3.3K	0.5% 1/10W
R666	1-216-651-11	METAL CHIP 1K	0.5% 1/10W
R671	1-216-603-11	METAL CHIP 10	0.5% 1/10W
R673	1-219-684-11	RES-CHIP 0.01	1% 1W
R674	1-216-809-11	METAL CHIP 100	5% 1/10W
R675	1-216-841-11	METAL CHIP 47K	5% 1/10W
R676	1-216-829-11	METAL CHIP 4.7K	5% 1/10W
R677	1-216-619-11	METAL CHIP 47	0.5% 1/10W
R679	1-219-684-11	RES-CHIP 0.01	1% 1W
R680	1-216-809-11	METAL CHIP 100	5% 1/10W
R681	1-216-841-11	METAL CHIP 47K	5% 1/10W
R682	1-216-829-11	METAL CHIP 4.7K	5% 1/10W
Δ R683	1-215-880-00	METAL OXIDE 10	5% 2W F
R685	1-216-663-11	METAL CHIP 3.3K	0.5% 1/10W
R686	1-216-651-11	METAL CHIP 1K	0.5% 1/10W
R691	1-216-845-11	METAL CHIP 100K	5% 1/10W
R692	1-216-845-11	METAL CHIP 100K	5% 1/10W
R693	1-216-845-11	METAL CHIP 100K	5% 1/10W
R694	1-216-821-11	METAL CHIP 1K	5% 1/10W
R695	1-216-845-11	METAL CHIP 100K	5% 1/10W
R697	1-216-823-11	METAL CHIP 1.5K	5% 1/10W
R698	1-216-847-11	METAL CHIP 150K	5% 1/10W
R699	1-216-841-11	METAL CHIP 47K	5% 1/10W
		< THERMISTOR (POSITIVE) >	
THP601	1-804-301-11	THERMISTOR, CHIP	
		*****	
		FILTER BOARD *****	
		< CAPACITOR >	
C402	1-104-661-11	ELECT 330uF 20%	16V
C403	1-126-934-11	ELECT 220uF 20%	16V
C404	1-164-156-11	CERAMIC CHIP 0.1uF	25V
C405	1-164-156-11	CERAMIC CHIP 0.1uF	25V
C406	1-126-964-11	ELECT 10uF 20%	50V
C407	1-126-964-11	ELECT 10uF 20%	50V
C408	1-164-315-11	CERAMIC CHIP 470PF 5%	50V
C409	1-164-315-11	CERAMIC CHIP 470PF 5%	50V
C410	1-164-156-11	CERAMIC CHIP 0.1uF	25V
C411	1-164-156-11	CERAMIC CHIP 0.1uF	25V
C412	1-164-156-11	CERAMIC CHIP 0.1uF	25V
C501	1-164-230-11	CERAMIC CHIP 220PF 5%	50V
C502	1-126-964-11	ELECT 10uF 20%	50V
C503	1-126-964-11	ELECT 10uF 20%	50V
C505	1-136-165-00	FILM 0.1uF 5%	50V
C506	1-136-165-00	FILM 0.1uF 5%	50V

Ref. No.	Part No.	Description	Remark	Ref. No.	Part No.	Description	Remark
C507	1-131-686-31	FILM	0.033uF 5% 50V	Q501	8-729-120-28	TRANSISTOR 2SC1623-L5L6	
C508	1-131-689-31	FILM	0.056uF 5% 50V	Q502	8-729-120-28	TRANSISTOR 2SC1623-L5L6	
C509	1-136-165-00	FILM	0.1uF 5% 50V	Q503	8-729-026-49	TRANSISTOR 2SA1037AK-T146-R	
C510	1-131-688-31	FILM	0.047uF 5% 50V	Q505	8-729-120-28	TRANSISTOR 2SC1623-L5L6	
C511	1-131-698-31	FILM	0.33uF 5% 50V	Q506	8-729-027-44	TRANSISTOR DTC114TKA-T146	
C512	1-131-698-31	FILM	0.33uF 5% 50V	Q507	8-729-026-49	TRANSISTOR 2SA1037AK-T146-R	
C516	1-126-964-11	ELECT	10uF 20% 50V	Q508	8-729-027-24	TRANSISTOR DTA114TKA-T146	
C517	1-126-964-11	ELECT	10uF 20% 50V	Q551	8-729-119-79	TRANSISTOR 2SC2785-FEK	
C518	1-126-964-11	ELECT	10uF 20% 50V	Q552	8-729-119-77	TRANSISTOR 2SA1175-FEK	
C520	1-126-960-11	ELECT	1uF 20% 50V			< RESISTOR >	
C521	1-126-960-11	ELECT	1uF 20% 50V	R401	1-216-837-11	METAL CHIP 22K 5% 1/10W	
C533	1-162-927-11	CERAMIC CHIP	100PF 5% 50V	R402	1-216-837-11	METAL CHIP 22K 5% 1/10W	
C551	1-165-319-11	CERAMIC CHIP	0.1uF 50V	R403	1-216-849-11	METAL CHIP 220K 5% 1/10W	
C552	1-165-319-11	CERAMIC CHIP	0.1uF 50V	R404	1-216-849-11	METAL CHIP 220K 5% 1/10W	
C553	1-165-319-11	CERAMIC CHIP	0.1uF 50V	R405	1-216-846-11	METAL CHIP 120K 5% 1/10W	
C554	1-165-319-11	CERAMIC CHIP	0.1uF 50V	R406	1-216-833-11	METAL CHIP 10K 5% 1/10W	
C555	1-104-665-11	ELECT	100uF 20% 25V	R407	1-216-834-11	METAL CHIP 12K 5% 1/10W	
C556	1-104-665-11	ELECT	100uF 20% 25V	R408	1-216-851-11	METAL CHIP 330K 5% 1/10W	
C557	1-165-319-11	CERAMIC CHIP	0.1uF 50V	R409	1-216-833-11	METAL CHIP 10K 5% 1/10W	
C558	1-165-319-11	CERAMIC CHIP	0.1uF 50V	R410	1-216-845-11	METAL CHIP 100K 5% 1/10W	
C559	1-165-319-11	CERAMIC CHIP	0.1uF 50V	R411	1-216-841-11	METAL CHIP 47K 5% 1/10W	
C560	1-136-165-00	FILM	0.1uF 5% 50V	R412	1-216-825-11	METAL CHIP 2.2K 5% 1/10W	
		< CONNECTOR >		R413	1-216-841-11	METAL CHIP 47K 5% 1/10W	
CN401	1-564-709-11	PIN, CONNECTOR (SMALL TYPE) 7P		R503	1-216-841-11	METAL CHIP 47K 5% 1/10W	
CN402	1-564-505-11	PLUG, CONNECTOR 2P		R504	1-216-841-11	METAL CHIP 47K 5% 1/10W	
CN403	1-564-506-11	PLUG, CONNECTOR 3P		R505	1-216-841-11	METAL CHIP 47K 5% 1/10W	
		< DIODE >		R506	1-216-841-11	METAL CHIP 47K 5% 1/10W	
D401	8-719-988-61	DIODE 1SS355TE-17		R508	1-216-833-11	METAL CHIP 10K 5% 1/10W	
D402	8-719-988-61	DIODE 1SS355TE-17		R509	1-216-809-11	METAL CHIP 100 5% 1/10W	
D403	8-719-988-61	DIODE 1SS355TE-17		R510	1-216-833-11	METAL CHIP 10K 5% 1/10W	
D404	8-719-988-61	DIODE 1SS355TE-17		R511	1-216-847-11	METAL CHIP 150K 5% 1/10W	
D405	8-719-109-93	DIODE RD6.2ESB2		R512	1-216-833-11	METAL CHIP 10K 5% 1/10W	
D500	8-719-988-61	DIODE 1SS355TE-17		R513	1-216-829-11	METAL CHIP 4.7K 5% 1/10W	
D501	8-719-988-61	DIODE 1SS355TE-17		R514	1-216-833-11	METAL CHIP 10K 5% 1/10W	
D551	8-719-110-41	DIODE RD15ESB2		R515	1-216-833-11	METAL CHIP 10K 5% 1/10W	
D552	8-719-110-41	DIODE RD15ESB2		R516	1-216-833-11	METAL CHIP 10K 5% 1/10W	
		< FERRITE BEAD >		R517	1-216-838-11	METAL CHIP 27K 5% 1/10W	
FB501	1-410-397-21	FERRITE 1.1uH		R518	1-216-839-11	METAL CHIP 33K 5% 1/10W	
		< IC >		R519	1-216-833-11	METAL CHIP 10K 5% 1/10W	
IC401	8-759-909-71	IC BA4558F		R520	1-216-833-11	METAL CHIP 10K 5% 1/10W	
IC402	8-759-700-07	IC NJM2903M		R521	1-216-841-11	METAL CHIP 47K 5% 1/10W	
IC501	8-759-909-71	IC BA4558F		R522	1-216-845-11	METAL CHIP 100K 5% 1/10W	
IC502	8-759-909-71	IC BA4558F		R523	1-216-841-11	METAL CHIP 47K 5% 1/10W	
IC503	8-759-909-71	IC BA4558F		R524	1-216-833-11	METAL CHIP 10K 5% 1/10W	
		< FERRITE BEAD >		R525	1-216-829-11	METAL CHIP 4.7K 5% 1/10W	
L551	1-410-397-21	FERRITE 1.1uH		R526	1-216-829-11	METAL CHIP 4.7K 5% 1/10W	
L552	1-410-397-21	FERRITE 1.1uH		R527	1-216-833-11	METAL CHIP 10K 5% 1/10W	
		< TRANSISTOR >		R528	1-216-834-11	METAL CHIP 12K 5% 1/10W	
Q401	8-729-027-31	TRANSISTOR DTA124EKA-T146		R530	1-216-833-11	METAL CHIP 10K 5% 1/10W	
Q402	8-729-901-00	TRANSISTOR DTC124EK		R531	1-216-833-11	METAL CHIP 10K 5% 1/10W	
Q403	8-729-026-49	TRANSISTOR 2SA1037AK-T146-R		R533	1-216-833-11	METAL CHIP 10K 5% 1/10W	
Q404	8-729-119-79	TRANSISTOR 2SC2785-FEK		R535	1-216-821-11	METAL CHIP 1K 5% 1/10W	
				R536	1-216-821-11	METAL CHIP 1K 5% 1/10W	
				R551	1-247-843-11	CARBON 3.3K 5% 1/4W	
				R552	1-247-843-11	CARBON 3.3K 5% 1/4W	

# SA-FT7ED/WFT7/SS-CNF7ED/FRF7ED/WS-FT7

**FILTER** **INPUT** **LED** **POWER**

Ref. No.	Part No.	Description	Remark
		< SWITCH >	
S401	1-570-707-31	SWITCH, SLIDE (POWER SAVE)	
S501	1-570-707-31	SWITCH, SLIDE (PHASE)	
		< VARIABLE RESISTOR >	
VR501	1-227-696-11	RES, VAR 20K (BASS BOOST)	
VR502	1-227-696-11	RES, VAR 20K (LEVEL)	
*****			
	A-1119-249-A	INPUT BOARD, COMPLETE	
*****			
		< CAPACITOR >	
C701	1-162-927-11	CERAMIC CHIP 100PF 5%	50V
		< CONNECTOR >	
CN701	1-564-506-11	PLUG, CONNECTOR 3P	
		< JACK >	
J701	1-779-797-11	JACK, PIN 1P (INPUT)	
		< RESISTOR >	
R701	1-216-853-11	METAL CHIP 470K 5%	1/10W
*****			
		LED BOARD	
*****			
		< CAPACITOR >	
C801	1-164-156-11	CERAMIC CHIP 0.1uF	25V
C802	1-164-156-11	CERAMIC CHIP 0.1uF	25V
		< CONNECTOR >	
CN801	1-564-719-11	PIN, CONNECTOR (SMALL TYPE) 3P	
		< DIODE >	
LD801	8-719-025-62	LED SML1216WTP4 (ON/STANDBY)	
*****			
		POWER BOARD	
*****			
	4-931-757-31	SCREW (DIA. 2.6X8) (IT3B), TAPPING	
	7-685-646-79	SCREW +BVTP 3X8 TYPE2 IT-3	
		< CAPACITOR >	
△C101	1-165-529-11	MYLAR 0.22uF 10%	275V
△C103	1-165-528-11	MYLAR 0.1uF 10%	275V
△C104	1-113-920-11	CERAMIC 0.0022uF 20%	250V
△C105	1-113-920-11	CERAMIC 0.0022uF 20%	250V
△C106	1-161-964-11	CERAMIC 0.0047uF	250V
△C107	1-161-964-11	CERAMIC 0.0047uF	250V
△C110	1-113-920-11	CERAMIC 0.0022uF 20%	250V
△C111	1-100-956-11	ELECT(BLOCK) 820uF 20%	250V
		(US,CND)	
△C112	1-100-956-11	ELECT(BLOCK) 820uF 20%	250V
		(US,CND)	

Ref. No.	Part No.	Description	Remark
△C112	1-112-529-11	ELECT(BLOCK) 390uF 20%	450V (AEP,UK)
C113	1-165-319-11	CERAMIC CHIP 0.1uF	50V
C114	1-163-275-11	CERAMIC CHIP 0.001uF	50V
C115	1-126-964-11	ELECT 10uF 20%	50V
C116	1-126-963-11	ELECT 4.7uF 20%	50V
C117	1-165-319-11	CERAMIC CHIP 0.1uF	50V
C118	1-163-009-11	CERAMIC CHIP 0.001uF 10%	50V
C119	1-164-222-11	CERAMIC CHIP 0.22uF	25V
C120	1-163-021-11	CERAMIC CHIP 0.01uF 10%	50V
C121	1-126-947-11	ELECT 47uF 20%	35V
△C122	1-107-824-11	CERAMIC 220PF 5%	1KV
△C123	1-107-824-11	CERAMIC 220PF 5%	1KV
△C124	1-137-741-22	FILM 0.039uF 3%	800V
C127	1-126-950-11	ELECT 330uF 20%	35V
△C131	1-113-898-11	CERAMIC 330PF 10%	250V
C151	1-100-924-21	ELECT 2200uF 20%	35V
C152	1-100-924-21	ELECT 2200uF 20%	35V
C155	1-165-319-11	CERAMIC CHIP 0.1uF	50V
C156	1-165-319-11	CERAMIC CHIP 0.1uF	50V
△C202	1-113-924-11	CERAMIC 0.0047uF 20%	250V
△C203	1-113-924-11	CERAMIC 0.0047uF 20%	250V
C204	1-126-942-61	ELECT 1000uF 20%	25V
C205	1-164-156-11	CERAMIC CHIP 0.1uF	25V
C206	1-164-156-11	CERAMIC CHIP 0.1uF	25V
C207	1-164-156-11	CERAMIC CHIP 0.1uF	25V
C208	1-164-156-11	CERAMIC CHIP 0.1uF	25V
C209	1-126-960-11	ELECT 1uF 20%	50V
C210	1-165-319-11	CERAMIC CHIP 0.1uF	50V
		< CONNECTOR >	
CN201	1-564-321-00	PIN, CONNECTOR (3.96mm PITCH) 2P	
CN202	1-564-705-11	PIN, CONNECTOR (SMALL TYPE) 3P	
CN203	1-564-709-11	PIN, CONNECTOR (SMALL TYPE) 7P	
* CN205	1-564-511-11	PLUG, CONNECTOR 8P	
		< DIODE >	
△D101	8-719-082-57	DIODE D5SBA60F01	
D102	8-719-083-83	DIODE UDZS-TE17-15B	
D103	8-719-083-83	DIODE UDZS-TE17-15B	
D104	8-719-979-64	DIODE UF4005/23	
D105	8-719-083-83	DIODE UDZS-TE17-15B	
D106	8-719-083-83	DIODE UDZS-TE17-15B	
D107	8-719-063-70	DIODE D1NL20U	
D110	6-500-137-01	DIODE BAT54HT1	
D111	8-719-982-15	DIODE MTZJ-27B	
D151	6-501-225-01	DIODE D15XBN20	
D159	8-719-110-60	DIODE RD24ESB	
D201	8-719-991-33	DIODE 1SS133T-77	
D202	8-719-991-33	DIODE 1SS133T-77	
D203	8-719-991-33	DIODE 1SS133T-77	
D204	8-719-991-33	DIODE 1SS133T-77	
D205	8-719-991-33	DIODE 1SS133T-77	
D206	8-719-991-33	DIODE 1SS133T-77	
		< GROUND TERMINAL >	
EP151	1-537-770-21	TERMINAL BOARD, GROUND	

Ref. No.	Part No.	Description	Remark	Ref. No.	Part No.	Description	Remark
		< IC >		R212	1-216-841-11	METAL CHIP 47K 5%	1/10W
IC101	6-707-749-01	IC CXD9841P		R213	1-216-845-11	METAL CHIP 100K 5%	1/10W
		< LINE FILTER >				< RELAY >	
△ LF101	1-457-054-11	COIL, LINE FILTER (US,CND)		△ RY201	1-755-276-11	RELAY, POWER	
△ LF101	1-457-079-11	COIL, LINE FILTER (AEP,UK)		△ RY202	1-755-276-11	RELAY, POWER	
△ LF102	1-457-054-11	COIL, LINE FILTER (US,CND)				< TRANSFORMER >	
△ LF102	1-457-079-11	COIL, LINE FILTER (AEP,UK)		△ T101	1-443-720-11	TRANSFORMER, DC CONVERTER	
		< PHOTO COUPLER >		△ T201	1-443-717-11	TRANSFORMER, POWER (US,CND)	
PH101	6-600-187-01	PHOTO COUPLER PC123Y22FZ0F		△ T201	1-443-718-11	TRANSFORMER, POWER (AEP,UK)	
		< TRANSISTOR >				< THERMISTOR >	
Q101	6-551-339-01	FET 2SK3934(LBS2SONY,Q		△ TH101	1-805-841-21	THERMISTOR, NTC 3.0 (US,CND)	
Q102	6-551-339-01	FET 2SK3934(LBS2SONY,Q		△ TH101	1-805-842-21	THERMISTOR, NTC 6.0 (AEP,UK)	
Q201	8-729-027-31	TRANSISTOR DTA124EKA-T146		*****			
Q202	8-729-027-31	TRANSISTOR DTA124EKA-T146				SW BOARD	
Q203	8-729-120-28	TRANSISTOR 2SC1623-L5L6				*****	
Q204	8-729-026-49	TRANSISTOR 2SA1037AK-T146-R				< CAPACITOR >	
Q205	8-729-120-28	TRANSISTOR 2SC1623-L5L6		△ C301	1-113-915-11	CERAMIC 0.001uF 20% 250V	
Q206	8-729-027-31	TRANSISTOR DTA124EKA-T146				< CONNECTOR >	
Q207	8-729-901-00	TRANSISTOR DTC124EK		* CN301	1-580-230-11	PIN, CONNECTOR (PC BOARD) 2P	
Q208	8-729-901-00	TRANSISTOR DTC124EK		CN302	1-564-321-00	PIN, CONNECTOR (3.96mm PITCH) 2P	
		< RESISTOR >				< SWITCH >	
△ R101	1-219-759-11	METAL 1M 5%	1/2W F	△ S301	1-786-847-11	SWITCH, POWER (POWER)	
R111	1-245-478-21	METAL 470K 1%	1/4W				
R112	1-245-478-21	METAL 470K 1%	1/4W				
R113	1-216-673-11	METAL CHIP 8.2K 0.5%	1/10W				
R114	1-216-679-11	METAL CHIP 15K 0.5%	1/10W				
R115	1-216-627-11	METAL CHIP 100 0.5%	1/10W				
R116	1-216-627-11	METAL CHIP 100 0.5%	1/10W				
R117	1-249-923-11	CARBON 1K 1%	1/4W				
R118	1-249-393-11	CARBON 10 5%	1/4W				
R119	1-216-073-00	RES-CHIP 10K 5%	1/10W				
R120	1-249-393-11	CARBON 10 5%	1/4W				
R121	1-216-073-00	RES-CHIP 10K 5%	1/10W				
△ R122	1-219-984-51	METAL 0.1 5%	2W F				
R123	1-247-692-11	CARBON 22 5%	1/4W				
R124	1-216-821-11	METAL CHIP 1K 5%	1/10W				
R130	1-216-627-11	METAL CHIP 100 0.5%	1/10W				
R131	1-216-835-11	METAL CHIP 15K 5%	1/10W				
R132	1-249-899-11	CARBON 100 1%	1/4W				
R133	1-216-603-11	METAL CHIP 10 0.5%	1/10W				
R134	1-216-651-11	METAL CHIP 1K 0.5%	1/10W				
R151	1-216-817-11	METAL CHIP 470 5%	1/10W				
R152	1-216-821-11	METAL CHIP 1K 5%	1/10W				
R201	1-216-841-11	METAL CHIP 47K 5%	1/10W				
R202	1-216-845-11	METAL CHIP 100K 5%	1/10W				
R203	1-216-841-11	METAL CHIP 47K 5%	1/10W				
R205	1-216-841-11	METAL CHIP 47K 5%	1/10W				
R206	1-216-841-11	METAL CHIP 47K 5%	1/10W				
R207	1-216-841-11	METAL CHIP 47K 5%	1/10W				
R208	1-216-841-11	METAL CHIP 47K 5%	1/10W				
R209	1-216-841-11	METAL CHIP 47K 5%	1/10W				
R210	1-216-827-11	METAL CHIP 3.3K 5%	1/10W				
R211	1-216-823-11	METAL CHIP 1.5K 5%	1/10W				

